

GATE VALVES

BOLTED BONNET

GT CLASS 150

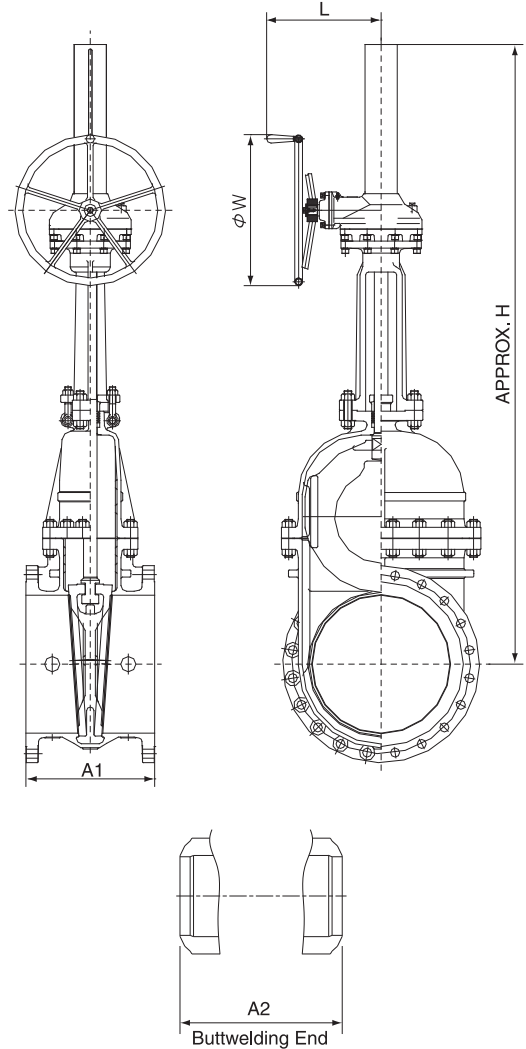
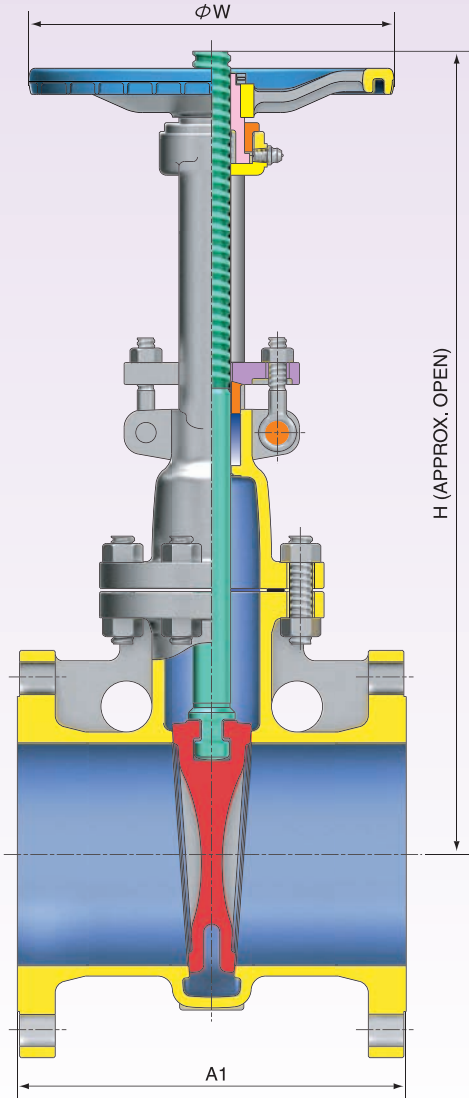

VALVE SIZE	in	2	2.5	3	4	6	8	10	12	14	16	18	20	24	28	30	36	
	mm	50	65	80	100	150	200	250	300	350	400	450	500	600	700	750	900	
A1	in	7.0	7.5	8.0	9.0	10.5	11.5	13.0	14.0	15.0	16.0	17.0	18.0	20.0	24.0	24.0	28.0	
	mm	178	190	203	229	267	292	330	356	381	406	432	457	508	610	610	711	
A3	in	8.5	9.5	11.1	12.0	15.9	16.5	18.0	19.8	22.5	24.0	26.0	28.0	32.0	36.0	36.0	40.0	
	mm	216	241	283	305	403	419	457	502	572	610	660	711	813	914	914	1016	
H	in	13.5	15.2	16.3	21.3	28.5	36.1	43.7	54.1	58.3	66.9	78.9	87.2	107.5	122.2	133.0	156.9	
	mm	342	386	415	542	725	916	1110	1375	1480	1700	2005	2215	2730	3105	3378	3985	
W	in	7.1	7.1	7.9	9.8	11.8	14.0	17.7	17.7	19.7	22.0	19.7	24.8	24.8	28.0	28.0	31.5	
	mm	180	180	200	250	300	355	450	450	500	560	500	630	630	710	710	800	
L	in	-	-	-	-	-	-	-	-	-	-	13.5	15.3	15.3	16.0	16.0	18.1	
	mm	-	-	-	-	-	-	-	-	-	-	342	389	389	406	406	461	
WEIGHT	RF	lb	35.3	48.5	55.1	83.8	143.3	224.9	326.3	480.6	760.6	1091.3	1278.7	1675.5	3029.2	4168.9	4334.3	6267.7
		kg	16	22	25	38	65	102	148	218	345	495	580	760	1374	1891	1966	2843
	BW	lb	30.9	39.7	50.7	75.0	127.9	189.6	280.0	434.3	694.5	1025.1	1201.5	1587.3	2689.6	3483.3	3648.6	6161.9
		kg	14	18	23	34	58	86	127	197	315	465	545	720	1220	1580	1655	2795