

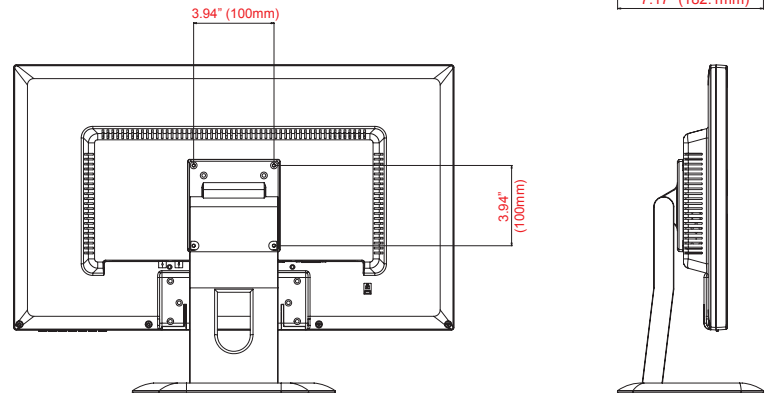

MODEL #	23LED-P
<b>DISPLAY</b>	
Screen Size	23"
Max. Resolution	1920 x 1080 @ 60Hz
Pixel Pitch	0.248mm x 0.248mm
Brightness	250cd/m <sup>2</sup> (Typical)
Contrast Ratio	1000:1
Aspect Ratio	16 : 9
Viewing Angle (H/V)	170°/160°
Display Color	16.7 Million
Response Time	< 5ms
Video System	NTSC / PAL
Frequency (H)	31 ~ 80KHz
Frequency (V)	56 ~ 75Hz
<b>INTERFACE</b>	
AV(Composite) In/ Out	2 / 2
S-Video In / Out	N / A
RGB In(15Pin D-Sub)	1
Component(Y, Pb, Pr, Sound L/R) In	N / A
DVI-In	1
HDMI In	1
Trigger In	1
AV(Composite) Sound In/Out (RCA Type)	1 / 0
PC Stereo In/Out	1 / 0
<b>AUDIO</b>	
Built in speaker	2 W x 2
<b>SPECIAL FEATURES</b>	
Multi Display Function	PIP / PBP / VOV
Filter Type	3D Comb filter / DeInterlace
Video Resolution(Max)	600 TV Line
Multi-lingual Language	English, Spanish, French, Italian Dutch, Portuguese or Nederland
<b>DIMENSIONS</b>	
Outline Dimension (W x H x D)	21.57" x 16.15" x 7.17" (547.9mm x 410.2mm x 182.1mm)
Net Weight	12.79 lbs (5.8 kg)
<b>MOUNT</b>	
VESA	100mm x 100mm
<b>GENERAL</b>	
Transmitter - IR Remote Control	YES
Power - Electrical Ratings	DC12V(AC100 ~ 240V[50/60Hz])
- Consumption	21.6W
Warranty - Parts/ Labor	3 Year / 3 Year
- MTBF (Approx.)	50,000 Hours
Operating Temperature	32 - 104°F / 0 - 40°C
Regulations	TUV-NRTL (=UL), CB, FCC(A), CE-Emc(LVD)
Compatible Mounts - WALL	VZ-WM05, VZ-WM10, VZ-WM30, VZ-WM31
- CEILING	VZ-CMK01, VZ-CMK05, VZ-CMK07
- RACK	N / A

### 23LED-P ADVANTAGES:

- 1080p Resolution
- 40% Lower Power Consumption
- BNC, HDMI, DVI, VGA
- 3D Comb-filter, De-interlace, Built-in Speakers
- 3-Year Warranty

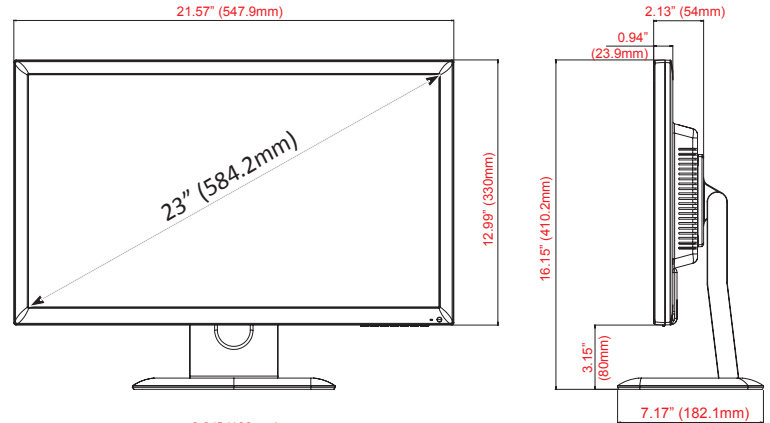

### INTERFACE

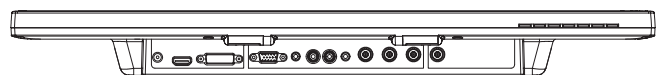

- 1 2 3 4 5 6 7 8 9 10 11

1. DC12V IN
2. HDMI
3. DVI
4. VGA
5. PC STEREO IN
6. AV(composite) SOUND IN
7. TRIGGER IN
8. AV(composite)1 IN
9. AV(composite)1 OUT
10. AV(composite)2 IN
11. AV(composite)2 OUT

### Contact Point

- <http://www.oriontechnology.co.kr>
- 1242 Apo industrial zone, In-ri, Apo-up, Gimchun-shi, Kyungbuk, Korea
- TEL: 82-54-430-8902 / FAX: 82-54-430-8904