

Flood Lighting Fixtures SGFD Series

Wet Locations
NEMA 3, 3R, 4, 4X, 7

❖ Type of Explosion-proof
Non Sparking (Ex nR II T3)

❖ Application

- SGFD Series flood lighting fixtures are used ;
- in hazardous areas, both indoors and outdoors where long life and low maintenance costs are desired.
 - in marine applications where water spray and corrosive atmospheres are considerations
 - in petroleum refineries, chemical, petrochemical and other heavy process industry facilities.
 - in heavy process industries having environments where flammable or explosive vapors or gases, or where combustible dusts are present.

❖ Certification

- Certified by KOSHA (Korea Occupational Safety & Health Agency), KGS (Korea Gas Safety Corporation), and the others.

❖ Compliance

- IEC 60079-0, 15
- NEMA 3, 3R, 4, 4X, 7
- IP55

❖ Standard Finish

- MUNSSELL No. 7.5BG 6/1.5
- If you want another color, contact us please.

❖ Projection Angle Adjustment

Vertical	60° up down
Horizontal	60° right and left

❖ Weight

Catalog No.	Weight
SGNFD 66040	31.5 Kg

❖ Features

- The body and mounting box are wired with flameproof SPFC flexible coupling.
- The body is one piece casting and the front flame incorporated with front glass and guard is hinged and fixed to the front of the body.
- The ballast is high quality one maintaining much safety on strength of enclosure.
- The mounting box has a turning base plate on the top and a large access cover for wiring on the side.

❖ Standard Materials

- Main Body & Reflector: Aluminum sheet
- Front Frame : Cast aluminium alloy
- Front Glass : Tempered plate glass
- Ballast Housing : Steel
- Wiring Tube : SPFC Flexible coupling
- Cradle : Steel
- Mounting Box : Cast aluminium alloy



<SGFD>

❖ Technical Data

Electrical Ratings	
Rated Voltage	AC110V/ 220V/ 240V (* See Below)
Rated Wattage	150W/ 175W/ 200W/ 250W/ 400W
Rated Frequency	50Hz/ 60Hz
Entry Sizes	1/2", 3/4", 1"

* Also you can order various voltage :
120V/ 208V/ 277V/ 460V

⇒ If you need more information, contact us please.

❖ Ordering Number

❖ Ordering Information

Lamp	Watt	Ordering No.	Certification
High Pressure Sodium	150	SGNFD 66015	Ex nR II T3
	200	SGNFD 66020	
	250	SGNFD 66025	
	400	SGNFD 66040	
Metal Halide	175	SGHFD 67017	
	250	SGHFD 67025	
	400	SGHFD 67040	
Mercury Vapor	200	SGMFD 65020	
	250	SGMFD 65025	
	400	SGMFD 65040	

SGNFD 660 15
 ① ② ③

- ① SGFD Flood Lighting Fixture
 - SGMFD - Mercury Vapour
 - SGNFD - High Pressure Sodium
 - SGHFD - Metal Halide
- ② : Lamp Type ③ : Lamp Wattage (W)
 650 - Mercury Vapour 15 - 150
 660 - H.P. Sodium 17 - 175
 670 - Metal Halide 20 - 200
 25 - 250
 40 - 400

❖ Photometric Data

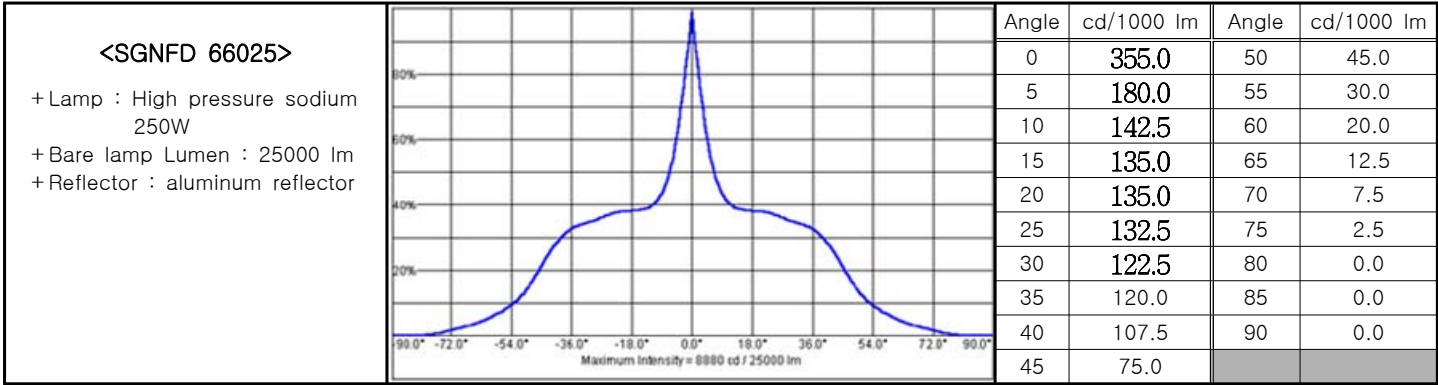

❖ Dimension

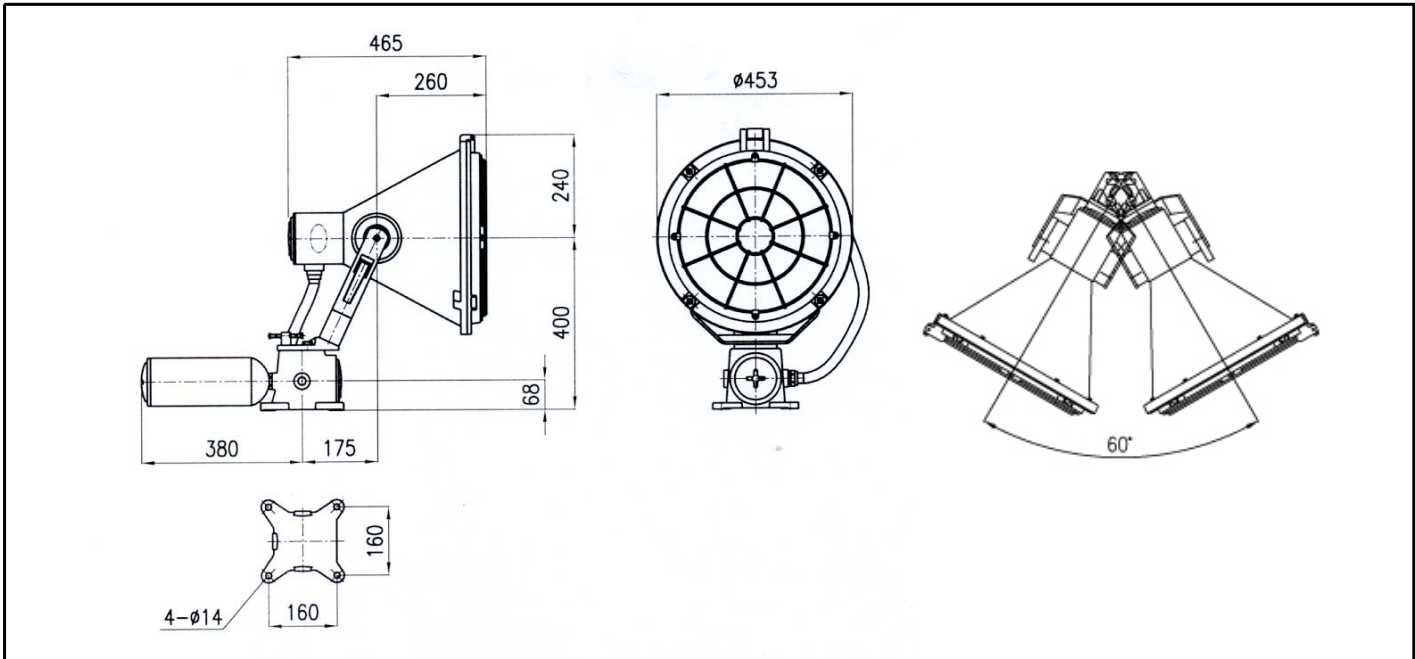

< SGFD >