

High Temperature & Low Sag Conductor

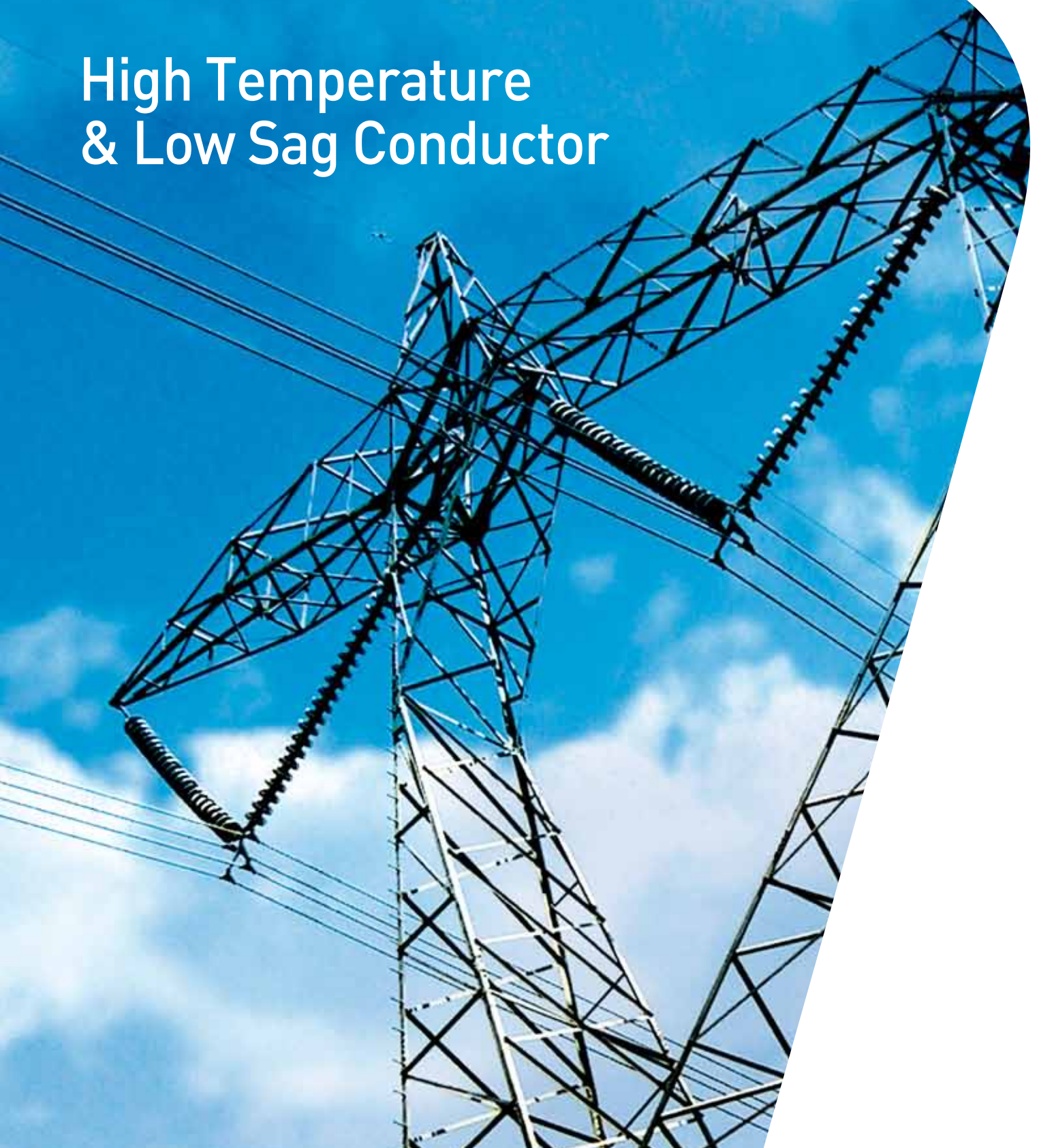
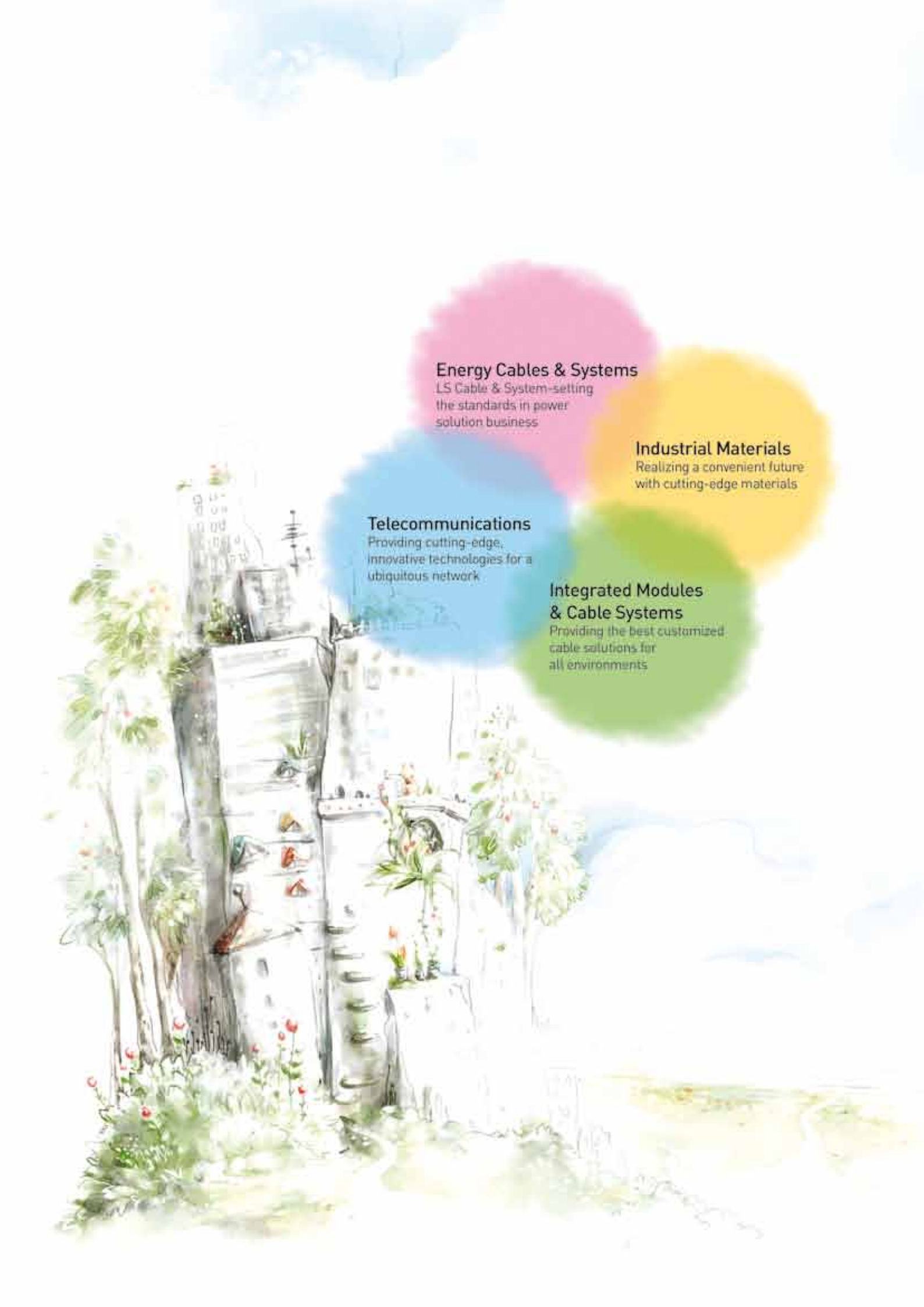

A watercolor illustration of a city street scene. In the foreground, there are green trees and bushes with small red flowers. A paved path leads towards the background. In the middle ground, there are several buildings, some with balconies and plants. A utility pole with wires is visible. The background shows a hazy cityscape under a bright sky with soft clouds. Four overlapping circles in pink, yellow, blue, and green are positioned in the upper right quadrant, each containing text.

Energy Cables & Systems

LS Cable & System-setting
the standards in power
solution business

Industrial Materials

Realizing a convenient future
with cutting-edge materials

Telecommunications

Providing cutting-edge,
innovative technologies for a
ubiquitous network

Integrated Modules & Cable Systems

Providing the best customized
cable solutions for
all environments

About LS Cable & System

Since the separation from LG Electronics in 2003, LS Group has specialized in industrial energy, electronic energy, and industrial materials. Thus, LS Group has achieved specialized global competitiveness in these fields. LS Group is a parent company of 40 subsidiary companies, including LS Cable & System, LSIS, LS Nikko Copper, LS Mtron, Gaon Cable, E1 and Yesco. LS Cable & System holds the unrivaled position of the top cable maker in Korea, and it provides total solutions for electronic power and telecommunication industries.

LS Cable & System has strived to become a global leader in the industry by implementing constant innovation since the establishment of the company. While providing high-quality solutions to help our clients, LS Cable & System is accelerating efforts to be the top player of the global cable industry by securing the top technologies in submarine cables and superconducting cables, as well as focusing on green business. Under the company vision 'Your No.1 Creative Partner,' LS Cable & System dedicates its best effort to deliver only the top technology and service to its clients.

Total Solution Provider for Electric Power and Telecommunication Industries

LS Cable & System, the longtime de facto holding company of LS Group, officially transformed into a holding company in July of 2008. The company's operations now encompass a total solution for electric power and telecommunication industries.

The latest change in corporate structure comes as the company is accelerating efforts to improve management efficiency in rapidly expanding markets. The move also results from efforts to effect a more responsible and transparent management structure. Management is now prepared to take more aggressive action to enhance our businesses and to identify new growth engines. The holding company will take the lead in fostering new growth engines and in identifying lucrative investment opportunities, while the company's other business units will focus on improving management and on making operations more efficient. With the continued support of the holding company, LS Cable & System will spearhead efforts to strengthen our business expertise, corporate competitiveness and management.

High Temperature & Low Sag Conductor

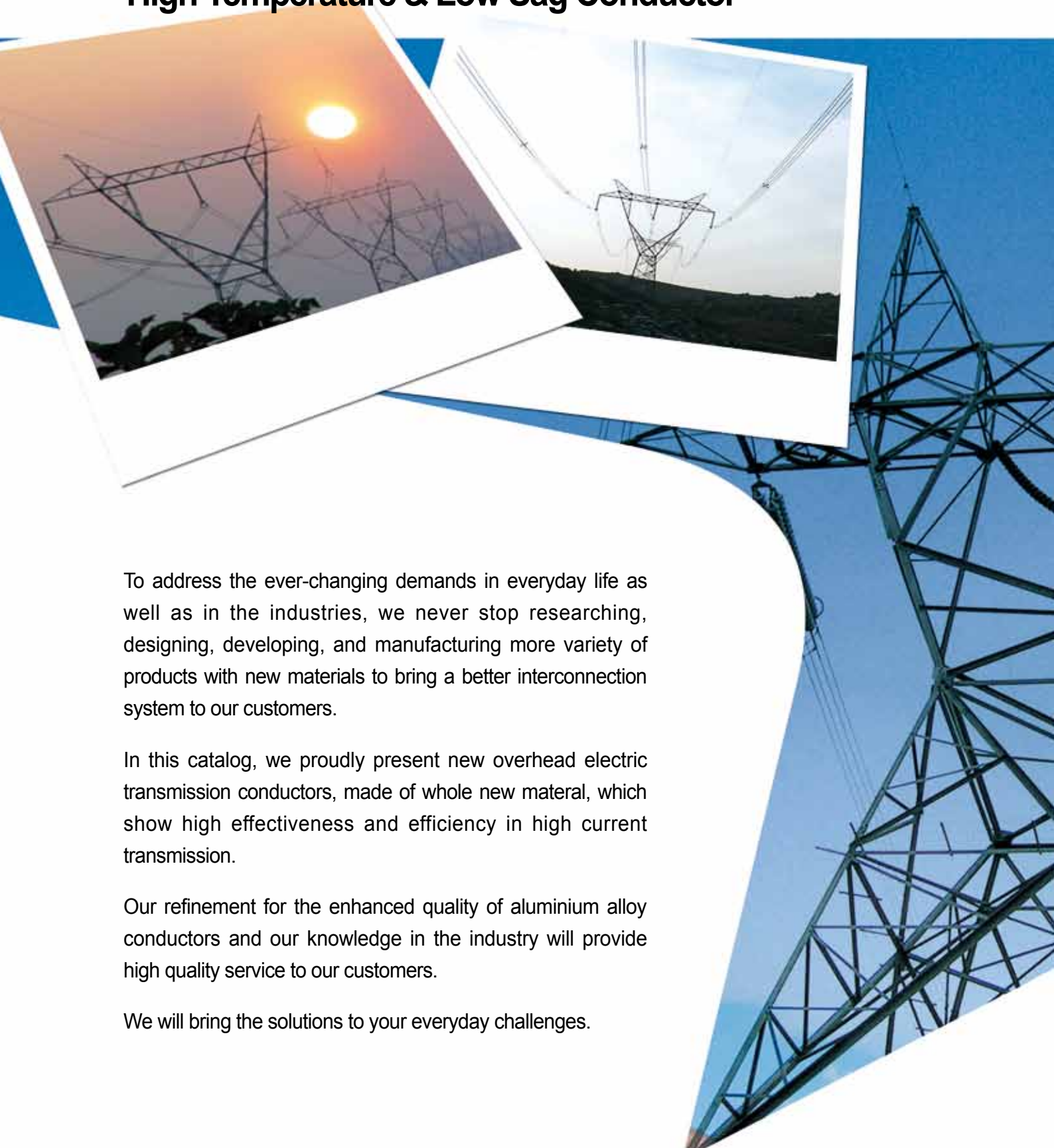

To address the ever-changing demands in everyday life as well as in the industries, we never stop researching, designing, developing, and manufacturing more variety of products with new materials to bring a better interconnection system to our customers.

In this catalog, we proudly present new overhead electric transmission conductors, made of whole new material, which show high effectiveness and efficiency in high current transmission.

Our refinement for the enhanced quality of aluminium alloy conductors and our knowledge in the industry will provide high quality service to our customers.

We will bring the solutions to your everyday challenges.



Contents

- 6 Trend in Developing Aluminum Conductors
- 7 Thermal Resistant Aluminum Alloy Conductors, Steel (Aluminum-clad Steel) Reinforced TACSR (AW)
- 10 High Tensile Strength Thermal Resistant Aluminum Alloy Conductors, Extra High Strength Steel Reinforced Hi-TACSR/EST
- 12 High Tensile Strength Thermal Resistant Aluminum Alloy Conductors, Aluminum-clad Steel Reinforced Hi-TACSR/AW
- 14 Super Thermal Resistant Aluminum Alloy Conductors, Aluminum-clad INVAR Reinforced STACIR/AW, Hi-STACIR/AW
- 20 Extra Thermal Resistant Aluminum Alloy Conductors Aluminum-clad INVAR Reinforced XTACIR
- 21 Gapped (Super) Thermal Resistant Aluminum Alloy Conductors, GTACSR, GSTACSR Extra High Tensile Strength Steel Reinforced

Trend in Developing Aluminum Conductors

- Our thermal resistant aluminum alloy conductors offer excellent performance and advantages with improved techniques, especially in the higher grade thermal resistant aluminum alloy conductors which is also reasonable in price.
- We have vast experience in producing thermal resistant aluminum alloy conductors as well as bare copper wires and aluminum conductors.

Kinds of Unique Aluminum Conductor Materials

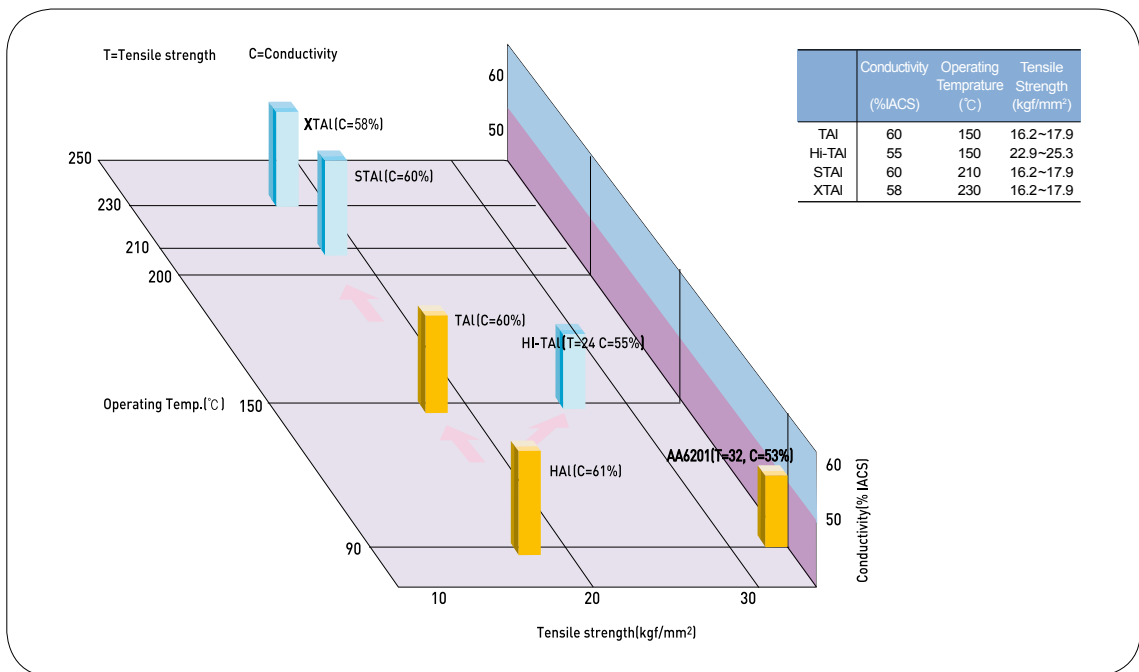

Approaching to the Upgrading Capacity

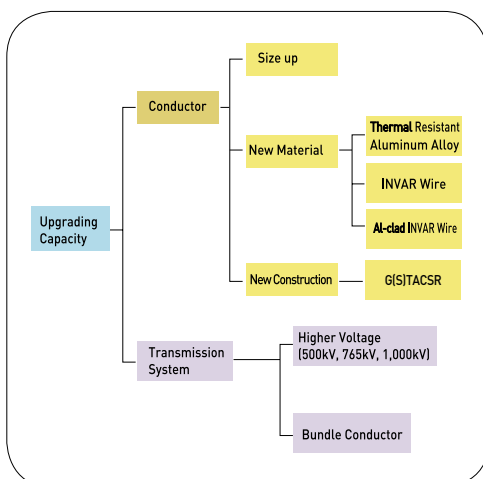

Flow of Developing the Overhead Transmission Conductor

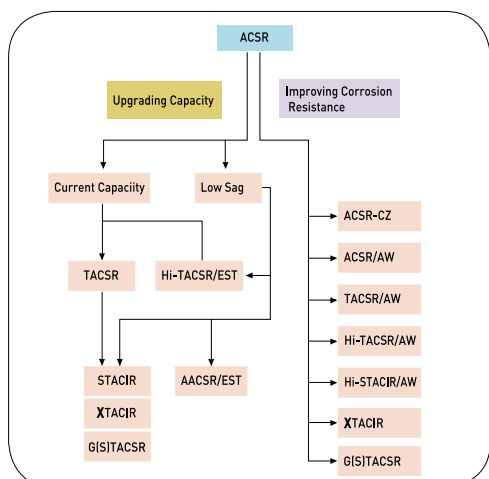

Thermal Resistant Aluminum Alloy Conductors, Steel (Aluminum-clad Steel) Reinforced



TACSR (/ AW)

Application

TACSR (/AW) is used for overhead electric power transmission lines. Big city, seaside district, moisture area etc.

Standard

IEC, ASTM, JEC 3406

Construction

- Core(St, AW): Zinc-coated Steel Wire / Aluminum-clad Steel Wire(AW) : 14% ~ 40% AW
- Conductor(TAI) : Thermal Resistant Aluminum Alloy Wire used for continuously allowable temperature up to 150°C

Characteristics

AW Type has excellent rustless characteristics.

TACSR

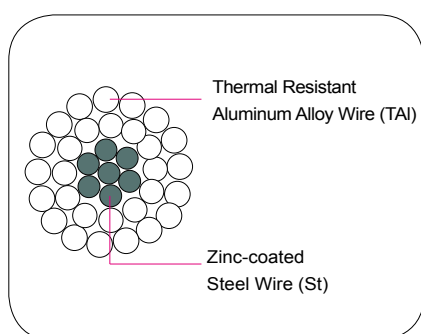

TACSR/AW

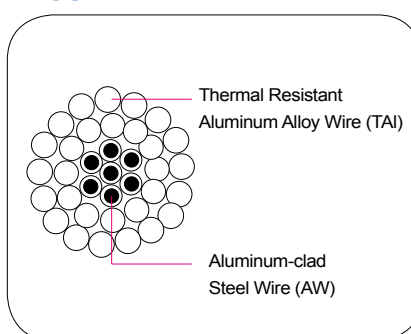

Thermal Resistant Aluminum Alloy Conductors, Steel (Aluminum-clad Steel) Reinforced

LS Cable & System Standard (60% IACS)

TACSR

Conductor Size (mm ²)	Stranding (Nos./mm)		Min. Breaking Load (kgf)	Reference												
				Cross-sectional Area (mm ²)			Overall Diameter (mm)		Weight (kg/km)			DC Resistance at 20°C (Ω/km)	Modulus of Elasticity (kgf/mm ²)	Coefficient of Linear Expansion (10 ⁻⁶ /°C)	Standard Length (m)	Current Carrying Capacity (A)
	TAI	ST		Total	TAI	ST	TAI	ST	Total							
58	6/3.5	1/3.5	1,980	57.73	9.621	67.35	10.5	3.5	158.1	75.04	233.1	0.505	8,400	18.9	1,000	343
80	6/4.2	1/4.2	2,770	83.10	13.85	96.95	12.6	4.2	227.5	108.0	335.5	0.350	8,400	18.9	1,000	430
95	6/4.5	1/4.5	3,810	95.40	15.90	111.3	13.5	4.5	261.2	124.0	385.2	0.306	8,400	18.9	1,000	478
80	15/2.6	4/2.6	4,720	79.64	21.24	100.9	13.0	7.8	219.2	166.5	385.7	0.368	9,390	17.6	2,000	448
100	15/2.9	4/2.9	5,580	99.08	26.42	125.5	14.5	8.7	272.8	207.1	479.9	0.296	9,390	17.6	2,000	517
120	15/3.2	4/3.2	5,550	120.6	32.17	152.8	16.0	9.6	332.2	252.2	584.4	0.243	9,390	17.6	2,000	590
120	30/2.3	7/2.3	5,540	124.7	29.09	153.8	16.1	6.9	345.7	228.0	573.7	0.237	9,080	18.0	2,000	598
160	30/2.6	7/2.6	6,980	159.3	37.16	196.5	18.2	7.8	441.5	291.3	732.8	0.185	9,080	18.0	2,000	706
200	30/2.9	7/2.9	8,640	198.2	46.24	244.4	20.3	8.7	549.3	362.4	911.7	0.149	9,080	18.0	2,000	816
240	30/3.2	7/3.2	10,210	241.3	56.29	297.6	22.4	9.6	668.9	441.3	1,110	0.122	9,080	18.0	2,000	932
330	26/4.0	7/3.1	10,950	326.8	52.84	379.6	25.3	9.3	905.4	414.2	1,320	0.0904	8,360	19.0	2,000	1,128
410	26/4.5	7/3.5	13,910	413.4	67.35	480.8	28.5	10.5	1,145	527.9	1,673	0.0714	8,360	19.0	2,000	1,322
480	45/3.7	7/2.47	11,260	483.8	33.54	517.34	29.6	7.41	1336.1	262.9	1,599	0.0610	7,250	20.8	2,000	1,425
520	54/3.5	7/3.5	15,600	519.5	67.35	586.9	31.5	10.5	1,441	527.9	1,969	0.0569	7,990	19.5	1,600	1,504
610	54/3.8	7/3.8	18,350	612.4	79.38	691.8	34.2	11.4	1,698	622.2	2,320	0.0481	7,990	19.5	1,600	1,682
680	54/4.0	7/4.0	19,810	678.8	87.99	766.8	36.0	12.0	1,882	689.8	2,572	0.0436	7,990	19.5	1,600	1,797
680	45/4.4	7/2.9	15,580	684.5	46.24	730.7	35.1	8.7	1,898	362.4	2,260	0.0431	7,250	20.8	1,600	1,787
810	45/4.8	7/3.2	18,480	814.5	56.29	870.8	38.4	9.6	2,259	441.3	2,700	0.0363	7,250	20.8	1,600	2,004
1,160	84/4.2	7/4.2	27,830	1,163	96.95	1,260	46.2	12.6	3,236	759.8	3,996	0.0254	7,430	20.5	1,200	2,573
1,520	84/4.8	7/4.8	36,390	1,520	126.7	1,647	52.8	14.4	4,228	993.3	5,222	0.0195	7,430	20.5	1,200	3,035

TACSR/AW (20.3% Conductivity AW)

Conductor Size (mm ²)	Stranding (Nos./mm)		Min. Breaking Load (kgf)	Reference									
				Cross-sectional Area (mm ²)		Overall Diameter (mm)		Weight (kg/km)	DC Resistance at 20°C (Ω/km)	Modulus of Elasticity (kgf/mm ²)	Coefficient of Linear Expansion (10 ⁻⁶ /°C)	Standard Length (m)	Current Carrying Capacity (A)
	TAI	AW		TAI	AW								
120	30/2.3	7/2.3	5,540	124.7	29.08	16.1	6.9	536.5	0.219	8,100	19.2	2,000	624
160	30/2.6	7/2.6	6,980	159.3	37.16	18.2	7.8	685.4	0.171	8,100	19.2	2,000	734
200	30/2.9	7/2.9	8,640	198.2	46.24	20.3	8.7	852.8	0.138	8,100	19.2	2,000	847
210	30/3.2	7/3.2	10,160	241.3	56.29	22.4	9.6	1,038	0.113	8,100	19.2	2,000	968
330	26/4.0	7/3.1	11,200	326.8	52.84	25.3	9.3	1,252	0.0856	7,620	20.0	2,000	1,159
410	26/4.5	7/3.5	14,230	413.4	67.35	28.5	10.5	1,587	0.0676	7,630	20.0	2,000	1,358
480	45/3.7	7/2.47	11,260	483.84	33.54	29.6	7.4	1,561	0.0595	6,910	21.5	2,000	1,437
520	54/3.5	7/3.5	15,920	519.5	67.35	31.5	10.5	1,883	0.0544	7,390	20.4	1,600	1,537
610	54/3.8	7/3.8	18,730	612.4	79.38	34.2	11.4	2,219	0.0461	7,330	20.4	1,600	1,717
680	45/4.4	7/2.9	15,580	684.5	46.24	35.1	8.7	2,201	0.0422	6,900	21.5	1,600	1,805
810	45/4.8	7/3.2	18,730	814.5	56.29	38.4	9.6	2,628	0.0354	6,910	21.5	1,600	2,028
950	84/3.8	7/3.8	23,780	952.6	79.38	41.8	11.4	3,170	0.0302	7,030	21.2	1,200	2,292
1,160	84/4.2	7/4.2	28,720	1,163	96.95	46.2	12.6	3,872	0.0247	7,030	21.2	1,200	2,606
1,520	84/4.8	7/4.8	37,520	1,520	126.7	52.8	14.4	5,060	0.0189	7,030	21.2	1,200	3,075

TACSR/AW (23% Conductivity AW)

Conductor Size (mm ²)	Stranding (Nos./mm)		Min. Breaking Load (kgf)	Reference									
	TAI	AW		Cross-sectional Area (mm ²)		Overall Diameter (mm)		Weight (kg/km)	DC Resistance at 20°C (Ω/km)	Modulus of Elasticity (kgf/mm ²)	Coefficient of Linear Expansion (10 ⁷ /°C)	Standard Length (m)	Current Carrying Capacity (A)
				TAI	AW	TAI	AW						
120	30/2.3	7/2.3	7/2.3	124.7	29.08	16.1	6.9	528.9	0.217	7,980	19.4	2,000	625
160	30/2.6	7/2.6	7/2.6	159.3	37.16	18.2	7.8	675.7	0.170	7,980	19.4	2,000	736
200	30/2.9	7/2.9	7/2.9	198.2	46.24	20.3	8.7	840.7	0.136	7,980	19.4	2,000	854
210	30/3.2	7/3.2	7/3.2	241.3	56.29	22.4	9.6	1,024	0.112	7,980	19.4	2,000	973
330	26/4.0	7/3.1	7/3.1	326.8	52.84	25.3	9.3	1,238	0.085	7,540	20.2	2,000	1,163
410	26/4.5	7/3.5	7/3.5	413.4	67.35	28.5	10.5	1,570	0.0671	7,550	20.2	2,000	1,363
480	45/3.7	7/2.47	7/2.47	483.84	33.54	29.6	7.4	1,550	0.0592	6,880	20.6	2,000	1,441
520	54/3.5	7/3.5	7/3.5	519.5	67.35	31.5	10.5	1,865	0.0541	7,330	20.6	1,600	1,541
610	54/3.8	7/3.8	7/3.8	612.4	79.38	34.2	11.4	2,198	0.0458	7,320	20.6	1,600	1,722
680	45/4.4	7/2.9	7/2.9	684.5	46.24	35.1	8.7	2,189	0.0420	6,860	21.6	1,600	1,809
810	45/4.8	7/3.2	7/3.2	814.5	56.29	38.4	9.6	2,613	0.0353	6,880	21.6	1,600	2,031
950	84/3.8	7/3.8	7/3.8	952.6	79.38	41.8	11.4	3,149	0.0300	6,980	21.3	1,200	2,299
1,160	84/4.2	7/4.2	7/4.2	1,163	96.95	46.2	12.6	3,847	0.0246	6,980	21.3	1,200	2,611
1,520	84/4.8	7/4.8	7/4.8	1,520	126.7	52.8	14.4	5,027	0.0189	6,980	21.3	1,200	3,075

Conductor Fittings

Compression Type Dead-end Clamp

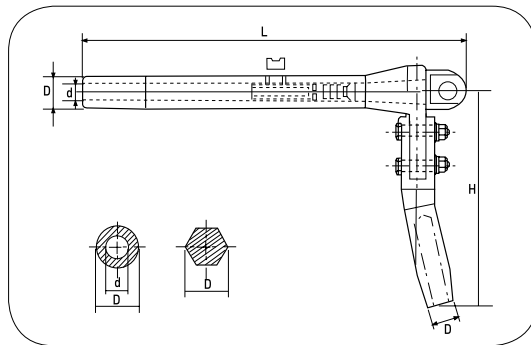

Conductor Size (mm ²)	Dimension (mm)				
	L	D	d	H	
TACSR (AW)	120	400~440	25~35	16~20	270~290
	160	400~440	25~35	18~22	270~290
	200	460~500	30~40	20~24	290~330
	240	500~530	35~42	22~26	310~330
	330	520~560	40~45	24~29	320~340
	410	600~630	46~50	28~32	170~390
	520	640~670	50~55	31~35	370~390
	610	700~740	57~63	34~38	380~410
	680	700~740	62~67	35~38	400~420
	810	720~760	65~70	38~42	430~440
	1,160	800~830	73~78	46~50	530~550
	1,520	940~1,000	87~93	52~57	600~620

Compression Type Joint Sleeve

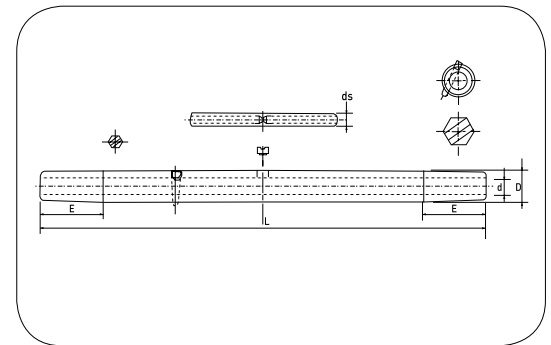

Conductor Size (mm ²)	Dimension (mm)					
	L	D	d	E	ds	
TACSR (AW)	120	470~530	25~35	16~20	55~65	7~8
	160	470~530	25~35	18~22	55~65	8~9
	200	500~560	30~40	20~24	65~75	9~10
	240	570~630	33~43	22~26	70~80	10~11
	330	610~670	37~47	25~29	80~90	9~10.5
	410	710~770	43~53	28~32	90~100	10.5~11.7
	610	900~960	55~65	34~38	115~125	11~13
	680	850~910	60~70	35~38	125~135	9~10
	810	910~970	63~73	38~42	130~140	10~11
	1,160	1,070~1,130	63~73	46~50	135~145	13~14
	1,520	1,310~1,370	85~95	53~57	175~185	14.5~15.5

High Tensile Strength Thermal Resistant Aluminum Alloy Conductors, Extra High Tensile Strength Steel Reinforced



Hi-TACSR / EST

Application

Hi-TACSR / EST is used for electric power transmission lines. River-crossing area, long span area, moisture area etc.

Standard

IEC, ASTM, JCS1363

Construction

- Core (EST) : Extra High Strength Steel Wire
- Conductor (Hi-TAI) : High Tensile Strength Thermal Resistant Aluminum Alloy Wire used for continuous allowable temperature up to 150°C
- If necessary, Conductor could be filled with grease (150°C grade)

Characteristics

Tensile strength of Hi-TAL wire is show in the below

Wire Diameter (mm)	Tensile Strength (kgf/mm ²)	Wire Diameter (mm)	Tensile Strength (kgf/mm ²)
4.2~5.0	Min. 22.9	2.9	Min. 25.0
4.0	Min. 24.3	2.6	Min. 25.3
3.2~3.8	Min. 24.6		

- Low sag & High tension characteristics
- High current carrying capacity characteristics
- Hi-TACSR/EST has high breaking load

Hi-TACSR / EST

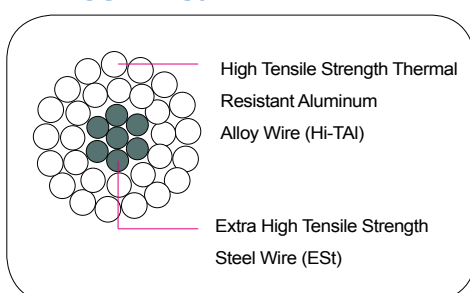

LS Cable & System Standard

Hi-TACSR / EST

Conductor Size (mm ²)	Stranding (Nos./mm)		Min. Breaking Load (kgf)	Reference							
	Hi-TAI	EST		Cross-Sectional Area (mm ²)		Overall Diameter (mm)		Weight (kg/km)	DC Resistance at 20°C (Ω/km)	Standard Length (m)	Current Carrying Capacity (A)
				Hi-TAI	EST	Hi-TAI	EST				
79	12/2.9	7/2.9	9,280	79.26	46.24	14.5	8.7	580.4	0.403	1,600	427
97	12/3.2	7/3.2	11,270	96.50	56.29	16.0	9.6	706.8	0.331	1,600	486
120	12/3.5	7/3.5	13,460	115.5	67.35	17.5	10.5	845.6	0.277	1,600	548
150	12/4.0	7/4.0	16,780	150.8	87.99	20.0	12.0	1,105	0.211	1,600	657
120	30/2.3	7/2.3	7,600	124.7	29.09	16.1	6.9	573.7	0.258	2,000	573
160	30/2.6	7/2.6	9,640	159.3	37.16	18.2	7.8	732.8	0.202	2,000	675
240	30/3.2	7/3.2	14,480	241.3	56.29	22.4	9.6	1,110	0.134	2,000	889
330	26/4.0	7/3.1	15,710	326.8	52.84	25.3	9.3	1,320	0.0983	2,000	1,082
410	26/4.5	7/3.5	19,420	413.4	67.35	28.5	10.5	1,673	0.0777	2,000	1,268
480	45/3.7	7/2.47	16,140	483.8	33.57	29.61	7.41	1,600	0.0664	2,000	1,362
610	54/3.8	7/3.8	25,720	612.4	79.38	34.2	11.4	2,320	0.0525	1,600	1,612
680	45/4.4	7/2.9	21,590	684.5	46.24	35.1	8.7	2,260	0.0470	1,600	1,715
810	45/4.8	7/3.2	25,900	814.5	56.29	38.4	9.6	2,700	0.0395	1,600	1,926
1160	84/4.2	7/4.2	38,770	1,163	96.95	46.2	12.6	3,996	0.0277	1,200	2,474
1520	84/4.8	7/4.8	50,700	1,520	126.7	52.8	14.4	5,222	0.0212	1,200	2,928

Conductor Fittings for Hi-TACSR/AW (EST)

Compression Type Dead-end Clamp

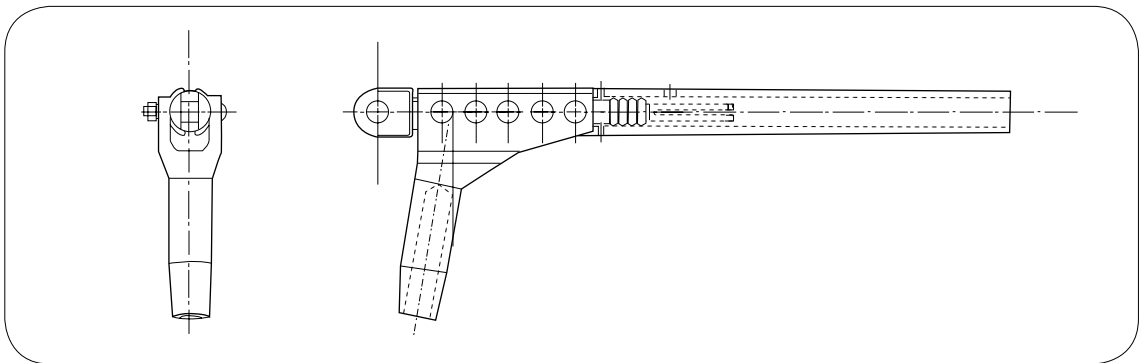

Compression Type Joint Sleeve

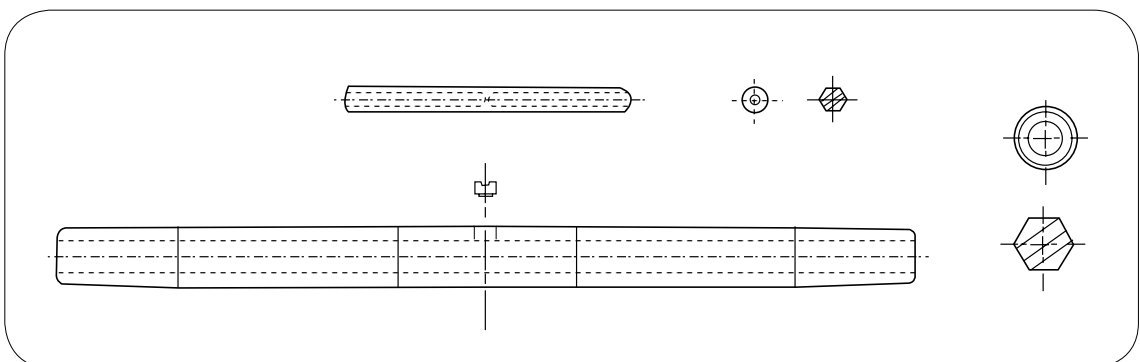

High Tensile Strength Thermal Resistant Aluminum Alloy Conductors, Aluminum-clad Steel Reinforced



Hi-TACSR / AW

Application

Hi-TACSR/AW is used for electric power transmission lines. River-crossing area, seaside district and overseas area, long span, mountain area etc.

Standard

IEC, ASTM, JCS1363

Construction

- Core (AW) : Aluminum-clad Steel Wire
- Conductor (Hi-TAI) : High Tensile Strength Thermal Resistant Aluminum Alloy Wire used for continuous allowable temperature up to 150°C

Characteristics

- Excellent rustless characteristics
- Low sag & high tension characteristics
- High current carrying capacity characteristics

Hi-TACSR / AW

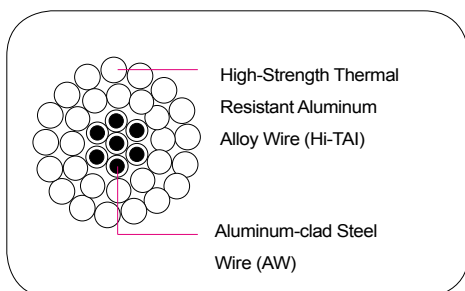

LS Cable & System Standard

Hi-TACSR / AW (20.3% Conductivity AW, 135kgf/mm²)

Conductor Size (mm ²)	Stranding (Nos./mm)		Min. Breaking Load (kgf)	Reference									
	Hi-TAI	AW		Cross-sectional Area (mm ²)		Overall Diameter (mm)		Weight (kg/km)	DC Resistance at 20°C (Ω/km)	Modulus of Elasticity (kgf/mm ²)	Coefficient of Linear Expansion (x10 ⁻⁷ /°C)	Standard Length (m)	Current Carrying Capacity (A)
				Hi-TAI	AW	Hi-TAI	AW						
79	12/2.9	7/2.9	7,400	79.26	46.24	14.5	8.7	521.4	0.331	9,930	16.9	1,600	471
97	12/3.2	7/3.2	9,010	96.50	56.29	16.0	9.6	634.9	0.272	9,930	16.9	1,600	536
120	12/3.5	7/3.5	10,750	115.5	67.35	17.5	10.5	759.7	0.227	9,930	16.9	1,600	605
150	12/4.0	7/4.0	14,000	150.8	87.99	20.0	12.0	992.5	0.173	9,930	16.9	1,600	728
120	30/2.3	7/2.3	6,420	124.7	29.09	16.1	6.9	536.5	0.237	8,260	19.2	2,000	598
160	30/2.6	7/2.6	8,140	159.3	37.16	18.2	7.8	685.0	0.186	8,260	19.2	2,000	704
240	30/3.2	7/3.2	12,210	241.3	56.29	22.4	9.6	1,038	0.123	8,260	19.2	2,000	928
330	26/4.0	7/3.1	13,560	326.8	52.84	25.3	9.3	1,252	0.0927	7,790	20.1	2,000	1,114
410	26/4.5	7/3.5	16,710	413.4	67.35	28.5	10.5	1,587	0.0732	7,800	20.0	1,600	1,306
610	54/3.8	7/3.8	23,200	612.4	79.38	34.2	11.4	2,219	0.0501	7,570	20.5	1,600	1,649
680	45/4.4	7/2.9	19,710	684.5	46.24	35.1	8.7	2,201	0.0458	7,090	21.5	1,600	1,736
810	45/4.8	7/3.2	23,630	814.5	56.29	38.4	9.6	2,628	0.0385	7,100	21.5	1,600	1,950
1,160	84/4.2	7/4.2	35,750	1,163	96.95	46.2	12.6	3,872	0.0269	7,220	21.2	1,200	2,507
1,520	84/4.8	7/4.8	46,670	1,520	126.7	52.8	14.4	5,060	0.0206	7,210	21.2	1,200	2,964

Hi-TACSR / AW (23% Conductivity AW, 130kgf/mm²)

Conductor Size (mm ²)	Stranding (Nos./mm)		Min. Breaking Load (kgf)	Reference									
	Hi-TAI	AW		Cross-sectional Area (mm ²)		Overall Diameter (mm)		Weight (kg/km)	DC Resistance at 20°C (Ω/km)	Modulus of Elasticity (kgf/mm ²)	Coefficient of Linear Expansion (x10 ⁻⁷ /°C)	Standard Length (m)	Current Carrying Capacity (A)
				Hi-TAI	AW	Hi-TAI	AW						
79	12/2.9	7/2.9	7,190	79.26	46.24	14.5	8.7	509.3	0.323	9,710	17.2	1,600	476
97	12/3.2	7/3.2	8,750	96.50	56.29	16.0	9.6	620.2	0.265	9,710	17.2	1,600	543
120	12/3.5	7/3.5	10,430	115.5	67.35	17.5	10.5	742.0	0.222	9,710	17.2	1,600	612
150	12/4.0	7/4.0	13,560	150.8	87.99	20.0	12.0	969.4	0.169	9,710	17.2	1,600	734
120	30/2.3	7/2.3	6,290	124.7	29.09	16.1	6.9	528.9	0.235	8,150	19.4	2,000	601
160	30/2.6	7/2.6	7,970	159.3	37.16	18.2	7.8	675.7	0.184	8,150	19.4	2,000	707
240	30/3.2	7/3.2	11,960	241.3	56.29	22.4	9.6	1,024	0.122	8,150	19.4	2,000	932
330	26/4.0	7/3.1	13,320	326.8	52.84	25.3	9.3	1,238	0.0920	7,710	20.2	2,000	1,118
410	26/4.5	7/3.5	16,390	413.4	67.35	28.5	10.5	1,570	0.0727	7,720	20.2	1,600	1,310
610	54/3.8	7/3.8	22,820	612.4	79.38	34.2	11.4	2,198	0.0497	7,500	20.7	1,600	1,656
680	45/4.4	7/2.9	19,510	684.5	46.24	35.1	8.7	2,189	0.0457	7,050	21.6	1,600	1,738
810	45/4.8	7/3.2	23,380	814.5	56.29	38.4	9.6	2,613	0.0384	7,060	21.6	1,600	1,952
1,160	84/4.2	7/4.2	35,310	1,163	96.95	46.2	12.6	3,847	0.0267	7,170	21.4	1,200	2,516
1,520	84/4.8	7/4.8	46,100	1,520	126.7	52.8	14.4	5,027	0.0205	7,170	21.4	1,200	2,971

Hi-TACSR / AW (23% Conductivity AW, 125kgf/mm²)

Conductor Size (mm ²)	Stranding (Nos./mm)		Min. Breaking Load (kgf)	Reference									
	Hi-TAI	AW		Cross-sectional Area (mm ²)		Overall Diameter (mm)		Weight (kg/km)	DC Resistance at 20°C (Ω/km)	Modulus of Elasticity (kgf/mm ²)	Coefficient of Linear Expansion (x10 ⁻⁷ /°C)	Standard Length (m)	Current Carrying Capacity (A)
				Hi-TAI	AW	Hi-TAI	AW						
79	12/2.9	7/2.9	6,990	79.26	46.24	14.5	8.7	509.3	0.323	9,710	17.2	1,600	476
97	12/3.2	7/3.2	8,500	96.50	56.29	16.0	9.6	620.2	0.265	9,710	17.2	1,600	543
120	12/3.5	7/3.5	10,120	115.5	67.35	17.5	10.5	742.0	0.222	9,710	17.2	1,600	612
150	12/4.0	7/4.0	13,190	150.8	87.99	20.0	12.0	969.4	0.169	9,710	17.2	1,600	734
120	30/2.3	7/2.3	6,160	124.7	29.09	16.1	6.9	528.9	0.235	8,150	19.4	2,000	601
160	30/2.6	7/2.6	7,800	159.3	37.16	18.2	7.8	675.7	0.184	8,150	19.4	2,000	707
240	30/3.2	7/3.2	11,710	241.3	56.29	22.4	9.6	1,024	0.122	8,150	19.4	2,000	932
330	26/4.0	7/3.1	13,080	326.8	52.84	25.3	9.3	1,238	0.0920	7,710	20.2	2,000	1,118
410	26/4.5	7/3.5	16,080	413.4	67.35	28.5	10.5	1,570	0.0727	7,720	20.2	1,600	1,310
610	54/3.8	7/3.8	22,510	612.4	79.38	34.2	11.4	2,198	0.0497	7,500	20.7	1,600	1,656
680	45/4.4	7/2.9	19,300	684.5	46.24	35.1	8.7	2,189	0.0457	7,050	21.6	1,600	1,738
810	45/4.8	7/3.2	23,130	814.5	56.29	38.4	9.6	2,613	0.0384	7,060	21.6	1,600	1,952
1,160	84/4.2	7/4.2	34,860	1,163	96.95	46.2	12.6	3,847	0.0267	7,170	21.4	1,200	2,516
1,520	84/4.8	7/4.8	45,540	1,520	126.7	52.8	14.4	5,027	0.0205	7,170	21.4	1,200	2,971

Super-Thermal Resistant Aluminum Alloy Conductors, Aluminum-clad Invar Reinforced



Hi-STACIR / AW, STACIR / AW

Application

Hi-STACIR/AW, STACIR/AW is normally used to up-rate an existing transmission line by simply replacing the existing conductor without tower modification or reinforcement.

Standard

IEC, ASTM, JCS 1405

Construction

- Core Wire (INVAR) : Aluminum-clad INVAR Wire/High Tensile Strength Aluminum-clad INVAR Wire
- Conductor (STAI) : Super Thermal Resistant Aluminum Alloy Wire used for continuous allowable temperature up to 210°C

Characteristics

- Double current carrying capacity of the same size ACSR
- No limitation for application area : Heavy wind, snow & galloping area
- Equivalent Sag-tension properties to conventional ACSR
- No modification & reinforcement on existing tower
- Easy installation with same method & equipments as ACSR's
- Low cost and short construction period
- Proved long-term reliability

STACIR/AW

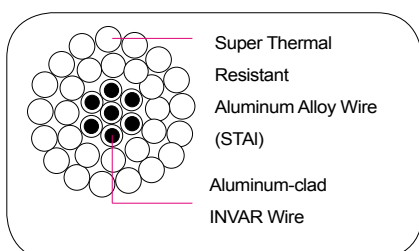

Hi-STACIR / AW

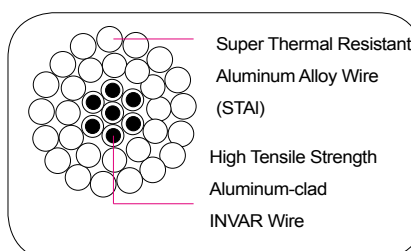

* INVAR : INVARIABLE to change of temperature
(a kind of Nickel-Ferrous Alloy)

Introduction of Hi-STACIR/AW, STACIR/AW

- Aluminum conductor INVAR reinforced is a completely different conductor compared to the conventional ACSR in capacity and thermal expansion keeping its size, weight and tensile strength. Aluminum conductor INVAR reinforced can carry twice as much conductor as that of ACSR of the same size while maximum sag and maximum working tension are the same as those of ACSR.
- The Hi-STACIR/AW, STACIR/AW makes it possible to approximately double the capacity of overhead power transmission lines by simply changing the electrical conductor without remodeling the steel towers.
- High conductive -(60%) and super thermal resistant aluminum alloy wires used for conductor layer can continuously be operated at higher temperature-210°C without degradation.
- when building new transmission line is inevitably accompanied not only by rights-of-way problems with the landowners but also by ecological and environmental impacts. Building new transmission lines is viewed to counter the current trend of preservation of environment in some area. Then the utilization of existing line with the right-of-way already obtained would be the solution to problem.
- Aluminum conductor strength INVAR reinforced is sure to satisfy you in terms of time, economy, and ecology because it can carry doubled conductor current of a conventional ACSR of the same size and this special feature realizes to double the load capability of the existing line utilizing the existing line facilities. It will set you free from right-of-way problems, tower modification, civil work and help preserve environment.
- High tensile strength INVAR wires (an Iron-Nickel alloy having very small thermal expansion property nearly 1/3 that of the steel) are used for the core that allow small thermal expansion resulting in small conductor sags. The INVAR wires are aluminum-clad so that the resistance against corrosion is improved.
- Now you will understand why mere replacement of existing ACSR with INVAR conductor can make the load capability of the existing line twofold.

Conclusion

Applying upgraded conductor

For the existing Line

- Double current carrying capacity
- No modification/ reinforcement on existing tower
- Short construction period with low cost

For New Line

- Reducing tower height
- Reducing tower site

Introduction to Hi-STACIR / AW, STACIR / AW

Characteristics of STAI and INVAR

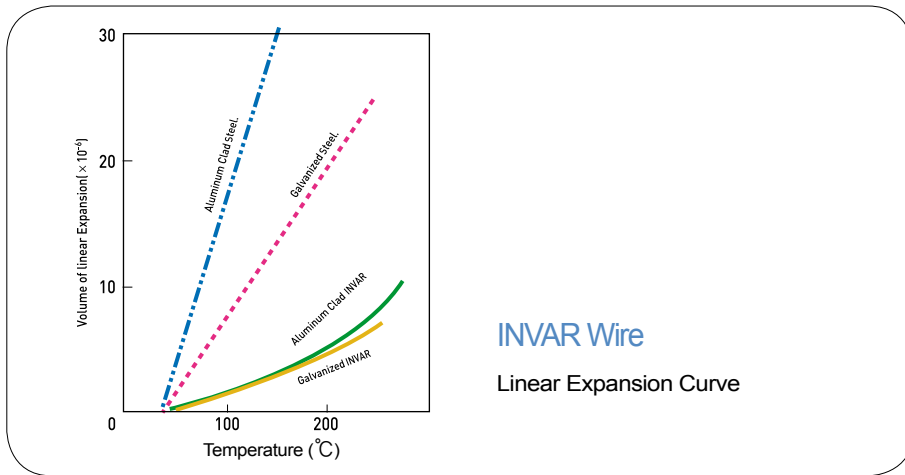
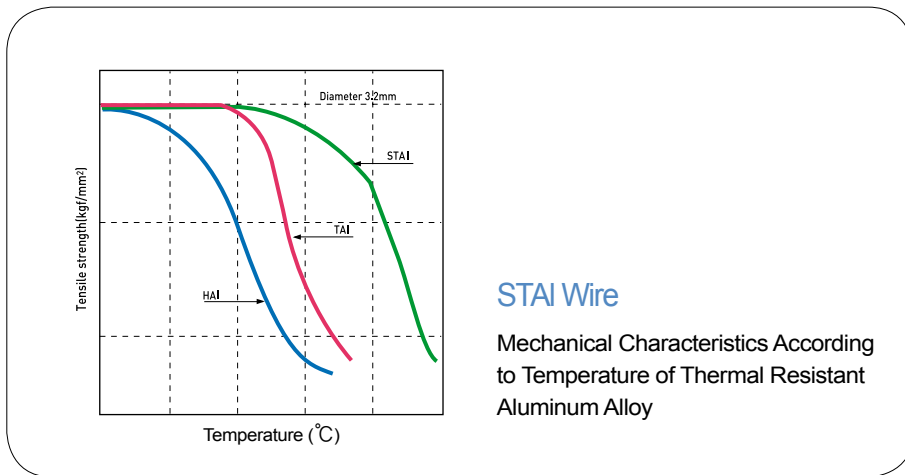

INVAR Wire

Item	Tensile Strength (kgf/mm ²)	Coefficient of Linear Expansion (x10 ⁻⁷ /°C)	Modulus of Elasticity (kgf/mm ²)	Applied Conductors
Galvanized INVAR Wire	105~110	2.8	16,500	STACIR
Al-clad INVAR Wire	105~110	3.7	15,500	STACIR/AW
High tensile strength Al-clad INVAR Wire	120~125	3.7	15,500	Hi-STACIR/AW

LS Cable & System Standard

STAI Wire

Standard Diameter (mm)	Tolerance of Dia. (mm)	Tensile Strength (kgf/mm ²)		Elongation on 250mm(%) Min	Reference				
		Min.	Avg		Cross-sectional Area (mm ²)	Weight (kg/km)	breaking Load (kgf)		DC Resistance at 20°C (Ω/km)
							Min.	Avg (Min.)	
2.6	±0.03	17.2	18.3	1.5	5.309	14.33	91.3	97.2	5.41
3.2	±0.04	16.5	17.6	1.7	8.042	21.71	133	142	3.57
3.38	±0.04	16.5	17.6	1.7	8.973	24.23	148	158	3.20
3.7	±0.04	16.5	17.2	1.8	10.75	29.03	177	185	2.67
4.0	±0.04	16.2	16.9	1.9	12.57	33.94	204	212	2.29
4.5	±0.04	16.2	16.9	2.0	15.90	42.93	258	269	1.81

Aluminum-clad INVAR Wire

Standard Diameter (mm)	Tolerance of Dia. (mm)	Tensile Strength (kgf/mm ²)	Elongation Min. (%)	No. of Twists (Nos.)	Conductivity (%IACS)	Properties of Aluminum		Reference						
						Thickness (mm)	Wrapping	Aluminum Thickness (mm)	Cross-sectional Area (mm ²)	Weight (kg/km)	breaking Load (kgf)	Coefficient of Linear Expansion		Modulus of Elasticity (kgf/mm ²)
												15°C~230°C (x10 ⁻⁶ /°C)	230°C~290°C (x10 ⁻⁶ /°C)	
2.47	±0.05	110	1.5	20	14	0.06	No separation between aluminum and invar core or no breakage	0.15	4.790	34.02	527	3.7	10.8	15,500
2.6	±0.05	110	1.5	20	14	0.06		0.15	5.309	37.69	584	3.7	10.8	15,500
3.1	±0.06	110	1.5	20	14	0.07		0.17	7.548	53.48	830	3.7	10.8	15,500
3.2	±0.06	110	1.5	20	14	0.07		0.17	8.042	57.10	885	3.7	10.8	15,500
3.38	±0.07	110	1.5	20	14	0.08		0.18	8.973	63.71	987	3.7	10.8	15,500
3.5	±0.07	110	1.5	20	14	0.08		0.18	9.621	68.31	1,060	3.7	10.8	15,500

High Tensile Strength Aluminum-clad INVAR Wire

Standard Diameter (mm)	Tolerance of Dia. (mm)	Tensile Strength (kgf/mm ²)	Elongation Min. (%)	No. of Twists (Nos.)	Conductivity (%IACS)	Properties of Aluminum		Reference						
						Thickness (mm)	Wrapping	Aluminum Thickness (mm)	Cross-sectional Area (mm ²)	Weight (kg/km)	breaking Load (kgf)	Coefficient of Linear Expansion		Modulus of Elasticity (kgf/mm ²)
												15°C~230°C (x10 ⁻⁶ /°C)	230°C~290°C (x10 ⁻⁶ /°C)	
2.47	±0.05	125	1.5	20	14	0.06	No separation between aluminum and invar core or no breakage	0.15	4.790	34.02	599	3.7	10.8	15,500
2.6	±0.05	120	1.5	20	14	0.06		0.15	5.309	37.69	637	3.7	10.8	15,500
3.1	±0.06	120	1.5	20	14	0.07		0.17	7.548	53.48	906	3.7	10.8	15,500
3.2	±0.06	120	1.5	20	14	0.07		0.17	8.042	57.10	965	3.7	10.8	15,500
3.38	±0.07	120	1.5	20	14	0.08		0.18	8.973	63.71	1,077	3.7	10.8	15,500
3.5	±0.07	120	1.5	20	14	0.08		0.18	9.621	68.31	1,155	3.7	10.8	15,500

LS Cable & System Standard

STACIR / AW

Conductor Size (mm ²)	Stranding (Nos./mm)		Min. Breaking Load (kgf)	Overall Diameter (mm)	Reference									
	STAI	INVAR			Cross-sectional Area (mm ²)			Weight (kg/km)			Modulus of Elasticity (kgf/mm ²)	Coefficient of Linear Expansion (10 ⁻⁷ /°C)	DC Resistance at 20°C (Ω/km)	Current Carrying Capacity (A)
					STAI	INVAR	Total	STAI	INVAR	Total				
160	30/2.6	7/2.6	6,140	18.20	159.30	37.16	196.46	441.7	265.2	706.9	8,040	16.0	0.1745	909
240	30/3.2	7/3.2	9,170	22.40	241.30	56.29	297.59	669.1	401.7	1070.8	8,040	16.0	0.1159	1,203
330	26/4.0	7/3.1	10,000	25.30	326.80	52.84	379.64	905.1	377.0	1282.1	7,580	17.5	0.0869	1,452
410	26/4.5	7/3.5	12,720	28.50	413.40	67.35	480.75	1145.5	480.6	1626.1	7,590	17.5	0.0686	1,708
480 (Rail)	45/3.7	7/2.47	10,500	29.61	483.84	33.54	517.38	1340.7	239.3	1580.0	6,900	20.0	0.0600	1,812
480 (Cardinal)	54/3.38	7/3.38	13,280	30.42	484.52	62.81	547.33	1343.5	452.2	1795.7	7,470	18.3	0.0591	1,846

Hi-STACIR/AW

Conductor Size (mm ²)	Stranding (Nos./mm)		Min. Breaking Load (kgf)	Overall Diameter (mm)	Reference									
	STAI	INVAR			Cross-sectional Area (mm ²)			Weight (kg/km)			Modulus of Elasticity (kgf/mm ²)	Coefficient of Linear Expansion (10 ⁻⁷ /°C)	DC Resistance at 20°C (Ω/km)	Current Carrying Capacity (A)
					STAI	INVAR	Total	STAI	INVAR	Total				
160	30/2.6	7/2.6	6,500	18.20	159.30	37.16	196.46	441.7	265.2	706.9	8,040	16.0	0.1745	909
240	30/3.2	7/3.2	9,700	22.40	241.30	56.29	297.59	669.1	401.7	1070.8	8,040	16.0	0.1159	1,203
330	26/4.0	7/3.1	10,500	25.30	326.80	52.84	379.64	905.1	377.0	1282.1	7,580	17.5	0.0869	1,452
410	26/4.5	7/3.5	13,300	28.50	413.40	67.35	480.75	1145.5	480.6	1626.1	7,590	17.5	0.0686	1,708
480 (Rail)	45/3.7	7/2.47	11,000	29.61	483.84	33.54	517.38	1340.7	239.3	1580.0	6,900	20.0	0.0600	1,812
480 (Cardinal)	54/3.38	7/3.38	13,800	30.42	484.52	62.81	547.33	1343.5	452.2	1795.7	7,470	18.3	0.0591	1,846

Comparison with Conventional ACSR

Conductor Size (mm ²)	Stranding (Nos./mm)			Weight (kg/km)	Overall Diameter (mm)	Breaking Load (kgf)	DC Resistant at 20°C (Ω/km)	Modulus of Elasticity ① (kgf/mm ²)	Coefficient of Linear Expansion ② (x10 ⁻⁷ /°C)	Continuous Current Capacity (A)
160	ACSR	HAI	30/2.6	732.8	18.2	6,990	0.182	9,080	18.0	454 (90°C)
		St	7/2.6							
160	Hi-STACIR/AW	STAI	30/2.6	706.9	18.2	6,500	0.1745	8,040 (15,500)	16.0 (3.7)	909 (210°C)
		INVAR	7/2.6							
240	ACSR	HAI	30/3.2	1,110	22.4	10,210	0.139	9,080	18.0	593 (90°C)
		St	7/3.2							
240	Hi-STACIR/AW	STAI	30/3.2	1,070.8	22.4	9,700	0.1159	8,040 (15,500)	16.0 (3.7)	1,203 (210°C)
		INVAR	7/3.2							
330	ACSR	HAI	26/4.0	1,260	25.3	10,950	0.0873	8,360	19.0	714 (90°C)
		St	7/3.1							
330	Hi-STACIR/AW	STAI	26/4.0	1,282.1	25.3	10,500	0.0869	7,580 (15,500)	17.5 (3.7)	1,452 (210°C)
		INVAR	7/3.1							
410	ACSR	HAI	26/4.5	1,673	28.5	13,890	0.0702	8,360	19.0	829 (90°C)
		St	7/3.5							
410	Hi-STACIR/AW	STAI	26/4.5	1,626.1	28.5	13,300	0.0686	7,590 (15,500)	17.5 (3.7)	1,708 (210°C)
		INVAR	7/3.5							
480 (Rail)	ACSR	HAI	45/3.7	1,599	29.61	11,800	0.05994	7,250	20.8	891 (90°C)
		St	7/2.47							
480 (Rail)	Hi-STACIR/AW	STAI	45/3.7	1,580	29.61	11,000	0.0600	6,900 (15,500)	20.0 (3.7)	1,812 (210°C)
		INVAR	7/2.47							
480 (Cardinal)	ACSR	HAI	54/3.38	1,836	30.42	15,300	0.0599	7,990	19.5	899 (90°C)
		St	7/3.38							
480 (Cardinal)	Hi-STACIR/AW	STAI	54/3.38	1,795.7	30.42	13,800	0.0591	7,470 (15,500)	18.3 (3.7)	1,846 (210°C)
		INVAR	7/3.38							

① () ; Modulus of Elasticity above the transition (knee) point temperature

② () ; Coefficient of linear expansion above the transition (knee) point temperature

Conductor Fittings

Compression Type Dead-end Clamp

Conductor size (mm ²)		Dimension (mm ²)				
		L	D	d	F	Ds
Hi-STACIR / AW STACIR (AW)	160	470 ~ 520	36 ~ 40	18 ~ 22	160 ~ 170	16 ~ 20
	240	505 ~ 560	40 ~ 44	22 ~ 26	175 ~ 185	20 ~ 24
	330	530 ~ 600	46 ~ 50	25 ~ 29	190 ~ 200	20 ~ 24
	410	620 ~ 680	50 ~ 54	31 ~ 35	195 ~ 205	22 ~ 26
	480	670 ~ 720	50 ~ 54	29 ~ 33	195 ~ 205	17 ~ 21

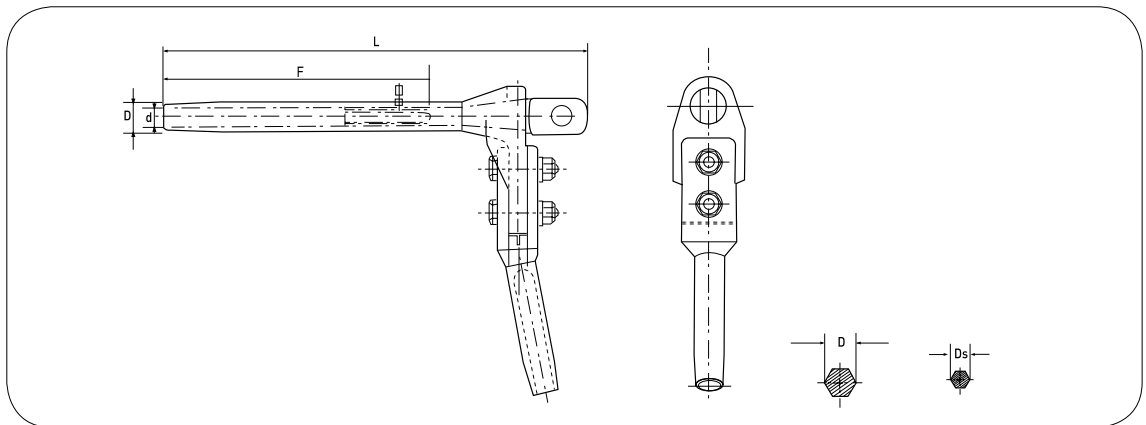

Compression Type Joint Sleeve

Conductor size		Dimension (mm ²)			
		L	D	d	Ds
Hi-STACIR / AW STACIR (AW)	160	550 ~ 640	36 ~ 40	18 ~ 22	160 ~ 200
	240	590 ~ 690	40 ~ 44	22 ~ 26	180 ~ 220
	330	650 ~ 750	46 ~ 50	25 ~ 29	180 ~ 220
	410	810 ~ 910	50 ~ 54	28 ~ 32	220 ~ 260
	480	850 ~ 880	50 ~ 54	29 ~ 33	220 ~ 260

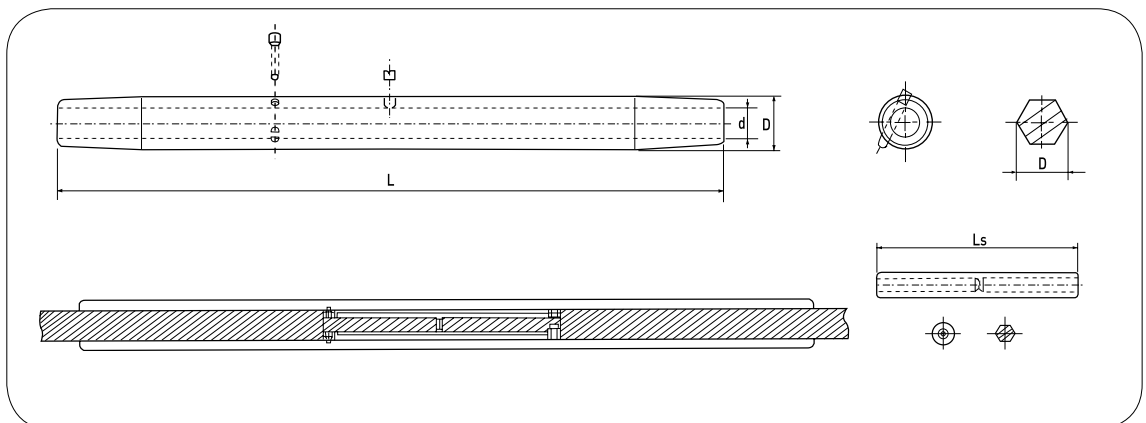

Extra Thermal Resistant Aluminum Alloy Conductors Aluminum-clad INVAR Reinforced

XTACIR / AW

Application

XTACIR is normally used to up-rate an existing transmission line by simply replacing the existing conductor without tower modification or reinforcement.

Standard

IEC, ASTM, JCS 1404

Construction

- Core wire (INVAR) : Aluminum-clad INVAR Wire
- Conductor (XTAI) : Extra Thermal Resistant Aluminum Alloy wire used for continuous allowable temperature up to 230°C



XTACIR / AW

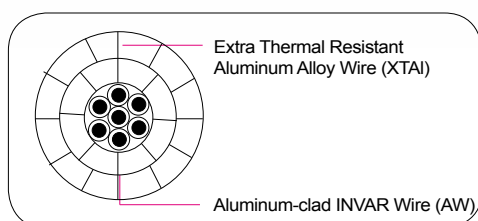

Characteristics

Conductor Size (mm ²)	Stranding (Nos./mm)		Min. Breaking Load (kN)	Reference														
	XTAI	INVAR		Cross-sectional Area (mm ²)			Overall Diameter (mm)		Weight (kg/km)			Modulus of Elasticity (kgf/mm ²)		Coefficient of Linear Expansion (x10 ⁻⁶ /°C)			DC Resistance at 20°C (Ω/km)	
				XTAI	INVAR	Total	XTAI	INVAR	XTAI	INVAR	Total	Up to transition point temperature	Over transition point temperature	Up to transition point temperature	Transition point temperature ~230°C	Over 230°C		
160	24/(2.85)	7/3.0	68.6	153.1	49.48	202.6	17.3	9.0	421.5	353.1	774.6	83.8	152.0	14.5	3.7	10.8	0.184	
200	24/(3.15)	7/3.4	83.4	187.0	63.55	250.6	19.2	10.2	515.1	453.5	968.6	84.7	152.0	14.2	3.7	10.8	0.150	
240	24/(3.45)	7/3.8	102.8	224.4	79.38	303.8	21.2	11.4	617.9	566.4	1,184	85.4	152.0	14.0	3.7	10.8	0.124	
320	24/(4.05)	7/3.8	114.3	309.1	79.38	388.5	23.8	11.4	851.4	566.4	1,418	80.2	152.0	15.5	3.7	10.8	0.0924	
400	24/(4.50)	7/4.3	139.8	381.6	101.6	483.2	26.6	12.9	1,051	725.3	1,776	80.8	152.0	15.4	3.7	10.8	0.0747	
600	28/(5.10)	7/5.0	197.1	572.0	137.5	709.5	32.2	15.0	1,575	980.7	2,556	79.3	152.0	15.8	3.7	10.8	0.0503	

Gapped (Super) Thermal Resistant Aluminum Alloy Conductors, Extra High Tensile Strength Steel Reinforced

GTACSR, GSTACSR

Application

GAP conductor, i.e. GTACSR and GSTACSR is normally used to up-rate an existing overhead transmission lines by simply replacing the existing conductor without tower modification or reinforcement.

Standard

- IEC 61089 – Round wire concentric lay overhead electrical stranded conductors
- IEC 62219 – Overhead electrical conductors - Formed wire, concentric lay, stranded conductors
- IEC 60888 – Zinc-coated steel wires for stranded conductors
- IEC 62004 – Thermal-resistant aluminum alloy wire for overhead line conductor

Construction

GAP conductor consists of Extra High Tensile Strength Galvanized Steel Wires in the center, (super) thermal-resistant aluminum alloy wires in conductor part and thermal-resistant grease in 'GAP' between steel core and aluminum inner layer. To maintain 'GAP' between steel core and aluminum inner layer, the aluminum inner layer shall be trapezoidal shaped.

Whereas outer aluminum layer could be round shaped or trapezoidal shaped in case of alternative compact designs.

- Core (EST) : Extra High Tensile Strength Galvanized Steel Wire
- Conductor (TAI, STAI) : (Super) Thermal Resistant Aluminum Alloy Wire
- Thermal-resistant grease in 'GAP' between steel core and aluminum inner layer
 - Provide water proofing
 - Protection for galvanizing coating on steel core
 - Lubrication between steel core and inner aluminum layer

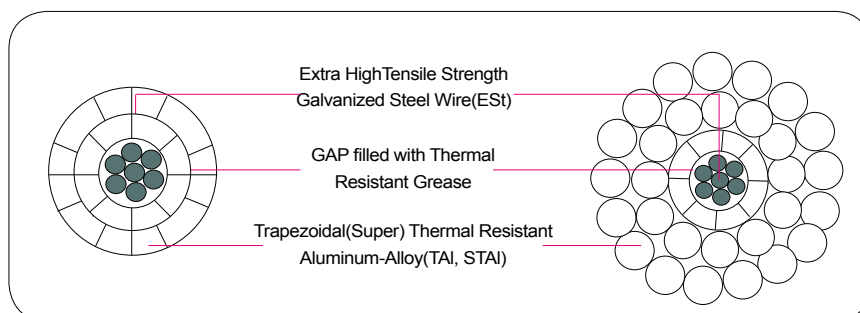

Characteristics

Conductor Size (mm ²)	Stranding (Nos./mm)		Min. Breaking Load (kgf)	Reference										
	(S)TAI	ESt		Cross-Sectional Area (mm ²)			Overall Diameter (mm)		Weight (kg/km)	DC Resistance at 20 °C (Ω/km)	Modulus of Elasticity (kgf/mm ²)	Coefficient of Linear Expansion (x10 ⁻⁶ /°C)	Current Carrying Capacity (A)	
				(S)TAI	ESt	Total	Conductor	ESt					ESt	ESt
150	10/TW (2.82) 14/TW (2.94)	7/2.0	6,030	157.5	21.99	179.5	16.4	6.0	624	0.1874	8,110	21,000	699	843
180	9/TW (3.03) 15/3.12	7/2.1	6,660	179.6	24.25	203.9	18.44	6.3	704	0.1640	8,050	21,000	773	934
200	11/TW (3.17) 18/2.8	7/2.4	8,160	197.6	31.67	229.3	19.7	7.2	813	0.1490	8,510	21,000	827	1,001
240	10/TW (3.69) 15/TW (3.46)	7/2.4	8,820	247.9	31.67	279.6	20.6	7.2	954	0.1188	7,970	21,000	939	1,137
290	10/TW (3.85) 16/3.75	7/2.6	10,370	293.1	37.17	330.3	23.3	7.8	1,124	0.1005	7,950	21,000	1,059	1,285
330	11/TW (3.98) 17/3.8	7/3.1	13,450	329.7	52.83	382.5	25.1	9.3	1,350	0.0893	8,330	21,000	1,149	1,396
370	9/TW (4.57) 15/4.35	7/2.7	11,950	370.6	40.08	410.7	26	8.1	1,363	0.0795	7,730	21,000	1,230	1,496
410	10/TW (4.58) 15/4.6	7/3.0	14,090	414.0	49.48	463.5	27.6	9.0	1,563	0.0711	7,870	21,000	1,324	1,612
480	10/TW (3.85) 17/3.4, 23/3.4	7/2.6	13,140	479.6	37.17	516.8	29.3	7.8	1,640	0.0614	7,360	21,000	1,418	1,728
540	11/TW (3.98) 18/3.5, 24/3.5	7/3.1	16,660	540.9	52.83	593.7	31.5	9.3	1,939	0.0545	7,610	21,000	1,539	1,877

① Other size are available if required.

② TW : Trapezoidal Wire

③ Current Carrying Capacity was calculated in accordance with IEEE Std 738 (2006) "Current-Temperature of Bare Overhead Conductors"
- Ambient air temp. : 40°C, Wind speed : 0.61m/s, Wind direction : 90o, Solar radiation : 0.1W/cm², Absorptivity & Emissivity : 0.5

Accessories

Appropriate design for dead-end clamp to carry large current is needed to reduce current heating and enhance heat radiation.

Other line hardware fittings are the same as conventional ACSR.

LS Cable & System provides line hardware fittings for use with GAP conductor.

*) If necessary semi-strain assembly is required for suspension tower to put additional tensioning function onto suspension tower to keep the low sag properties.

Installation

Installation method and procedure of GAP conductor is basically similar to those of conventional ACSR. Particular attention and a special sagging method is required to apply all tension to steel core only at sagging stage.

During period of installation, an experienced specialist from LS Cable & System can supervise and assist the installation work.

Cost Comparison Between STACIR and TACSR

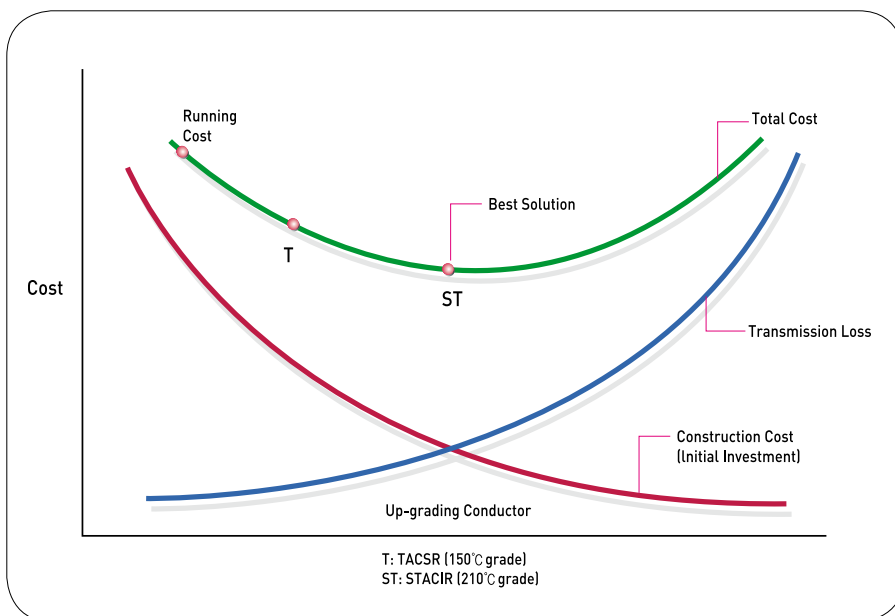
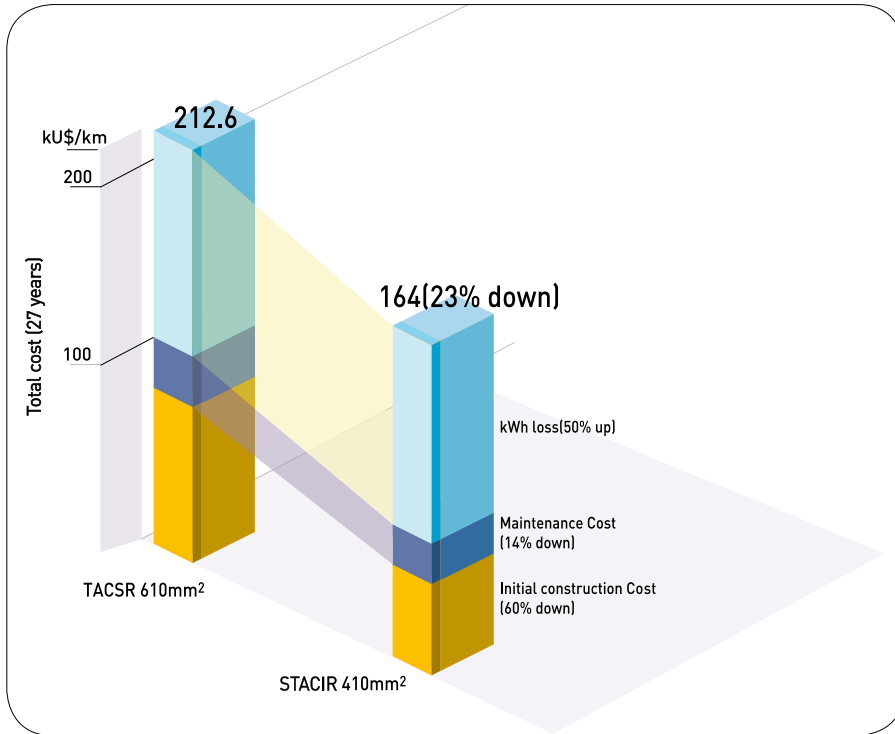

Products & Systems of LS Cable & System

A Convenient World through the Use of Cable

Energy Cables & Systems

LS Cable & System-setting the standards in power solution business

LS Cable & System provides highly customized electric power systems from power transmission & distribution solutions to marine, ship vessels, nuclear power and wind power systems.

Our turnkey solutions encompass the entire power transmission & distribution system from architecture, provision of raw materials, and installation, to maintenance and repair. We also lead the industry in developing cutting-edge products, such as superconducting cables, submarine cables and IT solutions for electric power.

We provide customized total solutions for a wide array of industries from nuclear power plants, manufacturing plants, railways, marine and ship vessel systems to wind power generation systems. Busduct system, which efficiently and effectively delivers high-capacity electricity, and the fire-retardant low toxic cables are a result of our decades-long commitment to creating eco-friendly products.

- Submarine Power Cable
- Super-conduction Cable System
- EHV, HV, MV, LV Cable
- OHTL, OPGW
- IT Solutions for Electric Power
- Control & Instrument Cable
- Halogen-free Cable
- Busduct System
- Industrial Specialty Cable



Telecommunications

Providing cutting-edge, innovative technologies for a ubiquitous network



Amid the convergence of broadcasting and telecommunications, and accelerating growth of broadband and wireless networks, the telecommunications industry is undergoing a major transformation. In this rapidly evolving landscape, LS Cable & System leads the industry with customized solutions and services that meets the demanding needs of our clients worldwide. We have developed the following solutions with the scalability to serve both the private and public sector: ① NI (Network Integration) / SI (System Integration), ② ITS (Intelligent Transport Solution), and ③ UTS (Ubiquitous Total Solution).

Our quest to remain at the forefront of network technology and trends has led us to develop the following cutting-edge products: fiber-optic telecom solution, 10G Ethernet-level converged integrated cabling system, RF coaxial cable system, G-PON-based FTTH solution and LS-HFC (Hybrid Fiber Coaxial), which is 200-Mbps high-speed cable TV network system. Our broad product portfolio and technical prowess have made us a market leader in the global telecommunications industry.

- Optical Fiber, Optical Fiber Cable
- FTTH Solutions
- RF Solutions
- Wireless Transmission System
- Coaxial Cable, UTP Cable
- QPS (Quadruple Play Service) System



Integrated Modules & Cable Systems

Providing the best customized cable solutions for all environments

Our dedication to meeting our clients need for faster, smaller, safer and more convenient products has kept us ahead of our peers on the technology curve. As such, our cables and modules are widely used in industrial installations, electronic devices, automobiles, aircrafts, and even military equipments and installations.

We have also maintained our commitment to developing a wide array of eco-friendly products that are safer, more efficient, and produce fewer pollutants.

Our technological breakthroughs have led us to the development of the following innovative products: MCX (Micro-Coaxial cables) for internal wiring of mobile phones, FA (Factory Automation) cables for plant automation systems, eco-friendly cables for LCDs, eco-friendly PP (Polypropylene) cables for automobiles, electric solutions for hybrid vehicles, and heat shrinkable tubes that can endure temperatures up to 135°C

- Industrial Cable & Module
- Automotive Wire & Cable
- Tube Components



Industrial Materials

Realizing a convenient future with cutting-edge materials



Based on LS Cable & System's production know-how and technologies in copper, aluminum and rubber treatment, the company is ramping up production of high value-added products, such as high-purity 8mm copper rods for vehicle wires and 0.03mm copper rod for ultra-fine wires.

The cutting-edge technologies of our precision rectangular winding wires, suitable for hybrid vehicle motors and car generators, and eXtra Thermal Aluminum Alloy (XTAL) are bolstering LS Cable & System's brand power here and abroad. Our continuous efforts to develop innovative new materials have also led us to produce oxide free copper (OFC), alternative to copper alloy, and so on. Furthermore, all these new developments are coming about as the company makes inroads in the global cable market through its localization efforts.

With years of experience and technologies in compounding treatment, LS Cable & System produces industrial rubber products and rubber tiles, the flooring material used in construction. Global demand for our flocking-based carpet tiles, featuring excellent convenience and sanitary engineering, is booming.

- Magnet Wires
- Copper Rod
- Aluminum Materials
- Rubber Tiles



Global Network

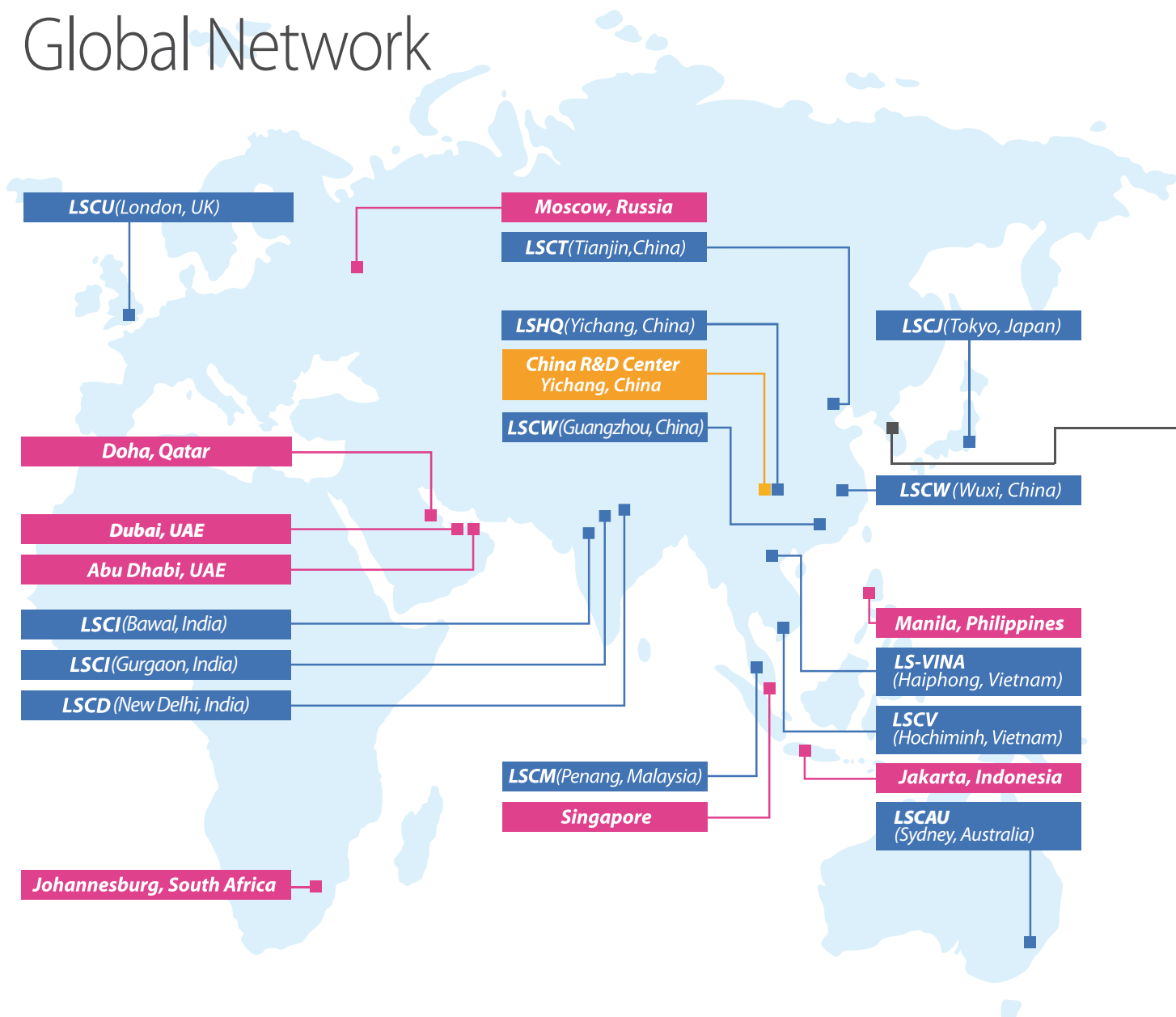

Branches

Abu Dhabi Office(U.A.E.)

Tel. +971-2-674-8780 Fax. +971-2-674-8781

Dubai Office(U.A.E.)

Tel. +971-4-344-4662 Fax. +971-2-674-8781

Singapore Office(Singapore)

Tel. +65-6342-9162~3 Fax. +65-6342-9165

Moscow Office(Russia)

Tel. +7-495-258-1805 Fax. +7-495-258-1806

Lima Office(Peru)

Tel. +51-1-434-6433

Johannesburg Office(South Africa)

Tel. +27-71-688-2028 Fax. +27-11-785-8327

Jakarta Office(Indonesia)

Tel. +62-21-797-4140 / 4013 Fax. +62-21-799-3071

Manila Office(Philippines)

Tel. +63-2-899-6169 / +63-2-962-2250 Fax. +632-962-2250

Doha Office(Qatar)

Tel. +974-4453-0333

Subsidiaries

LSCA(U.S.A.) : Marketing and Sales

Tel. +1-201-944-2005 Fax. +1-201-503-8130

LSCAU(Australia) : Marketing and Sales

Tel. +61-2-9460-0255 Fax. +61-2-9460-0355

LSCU(U.K.) : Marketing and Sales

Tel. +44-20-8899-6671 Fax. +44-20-8899-6673

LSCJ(Japan) : Marketing and Sales

Tel. +81-3-6205-7188 Fax. +81-3-6205-7187

LSCD(India) : Marketing and Sales

Tel. +91-11-4106-4242

LSHQ(China)

Tel. +86-717-667-7777

Production : EHV, LV/MV, Overhead Transmission Line, Industrial Specialty Cable & System

LSCT(China)

Tel. +86-22-2699-7618

Production : Magnet Wire

LSCW(China)

Tel. +86-510-8811-9000 Fax. +86-510-8534-5341

Production : Automotive Wire & Cable, Bus Duct, Electronic Wire & Cable, Tube, ACF, Accessories for EHV Cable System

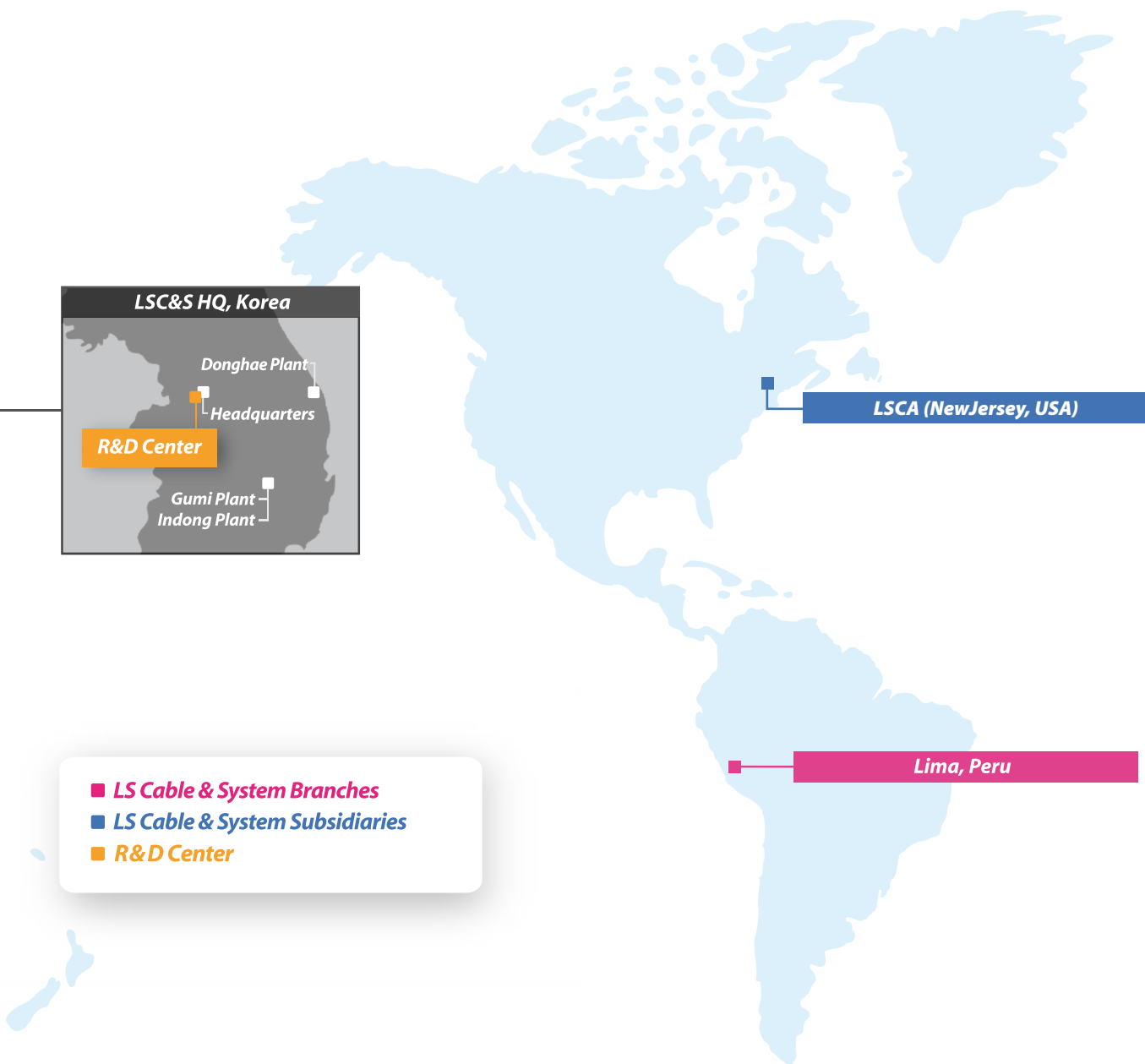

LSC&S HQ, Korea

Donghae Plant

Headquarters

R&D Center

Gumi Plant

Indong Plant

LSCA (New Jersey, USA)

Lima, Peru

- **LS Cable & System Branches**
- **LS Cable & System Subsidiaries**
- **R&D Center**

Beijing Office(Beijing)

Tel. +86-10-5761-3166 Fax. +86-10-5761-3160

Shenzhen Office(Shenzhen)

Tel. +86-755-8275-0470-1 Fax. +86-755-8275-0545

Guangzhou Office(Guangzhou)

Tel. +86-20-8326-6321 Fax. +86-20-8326-6270

LS-VINA(Vietnam)

Tel. +84-31-354-0141 Fax. +84-31-354-0142

Production : EHV, LV/MV, ACSR, OPGW, SCR

LSCV(Vietnam)

Tel. +84-61-356-9140 Fax. +84-61-356-9148

Production : Low Voltage Cable, UTP

LSCM(Malaysia)

Tel. +60-4-588-9609 Fax. +60-4-588-9607

Production : Magnet Wire

LSCI(India)

Gurgaon: Marketing & Sales

Tel. +91-124-428-5800-4 Fax. +91-124-428-5805

Bawal

Tel. +91-128-426-4267 Fax. +91-128-426-4364

Production : RF Feeder Cable, Network Solution, EHV, LV/MV, OPGW

China R&D Center

Tel. +86-717-667-7777

Korea Operations

Headquarter

Tel. +82-2-2189-9114

Gumi Plant

Tel. +82-54-469-7114

Production : Power Cable up to 500kV, OHTL, OPGW, Data Cable, RF Feeder System, Copper Rod, Magnet Wire

Indong Plant

Tel. +82-54-469-7763

Production : Industrial Cable & Module, Optical Cable, Aluminum Materials

Donghae Plant

Tel. +82-33-820-3114

Production : Submarine Cable, Industrial Specialty Cable

R&D Center

Tel. +82-31-450-8114



Greater Value Together
LS Cable & System

LS Cable & System
www.lscns.com

High Temperature & Low Sag Conductor
12-17F, LS Tower, 127 LS-ro, Dongan-gu, Anyang-si, Gyeonggi-do, 431-848, Korea
Tel. 82-2-2189-9114

©2016 LS Cable & System Ltd. All right reserved. This product or document is protected by copyright and distributed under licenses restricting its use, copying, distribution, and decompilation. No part of this product or document may be reproduced in any form by any means without prior written authorization of LS Cable & System and its licensors, if any. Products shown on this catalog are subject to change without any prior notice.