

HEAT TREAT :
 SURF. TREAT :
 GEN. CH. :

NO	DATE	SPEC. CHANGING	DGN	CH'G NO
△	2015.01.21	공차 변경 및 형상공차 추가	양태승	

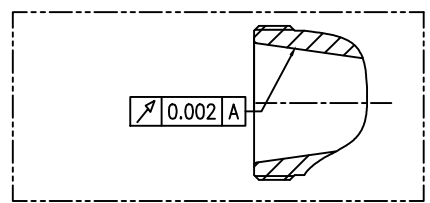
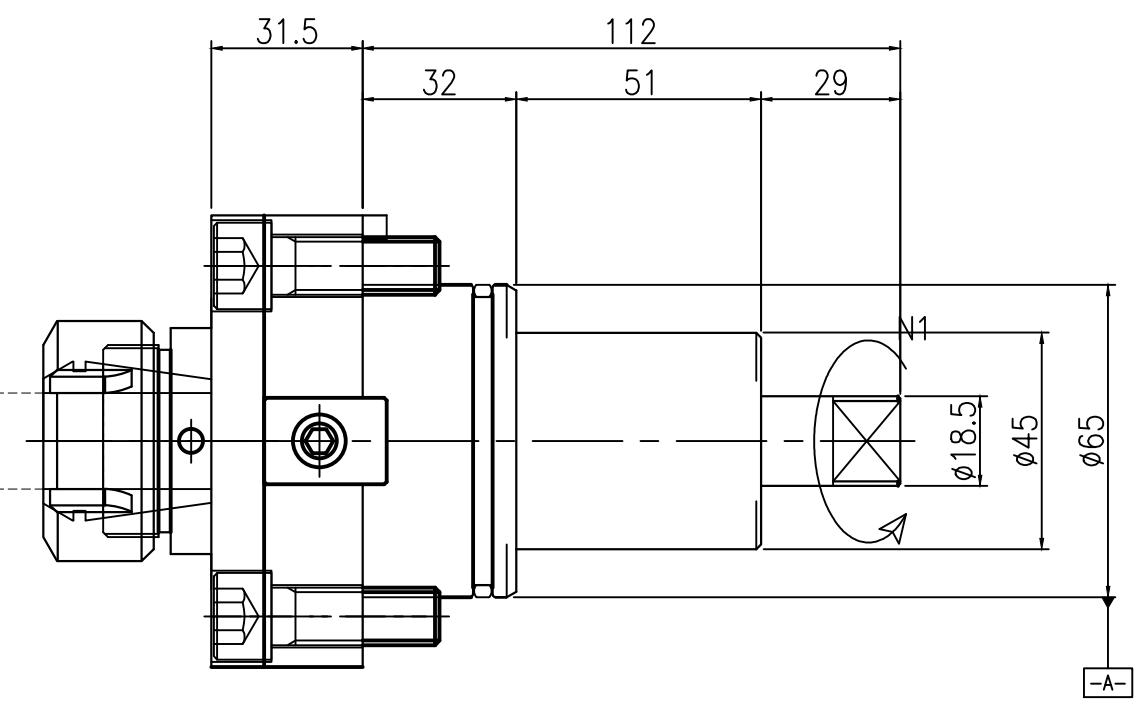
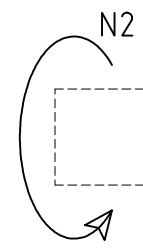
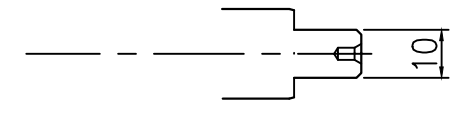
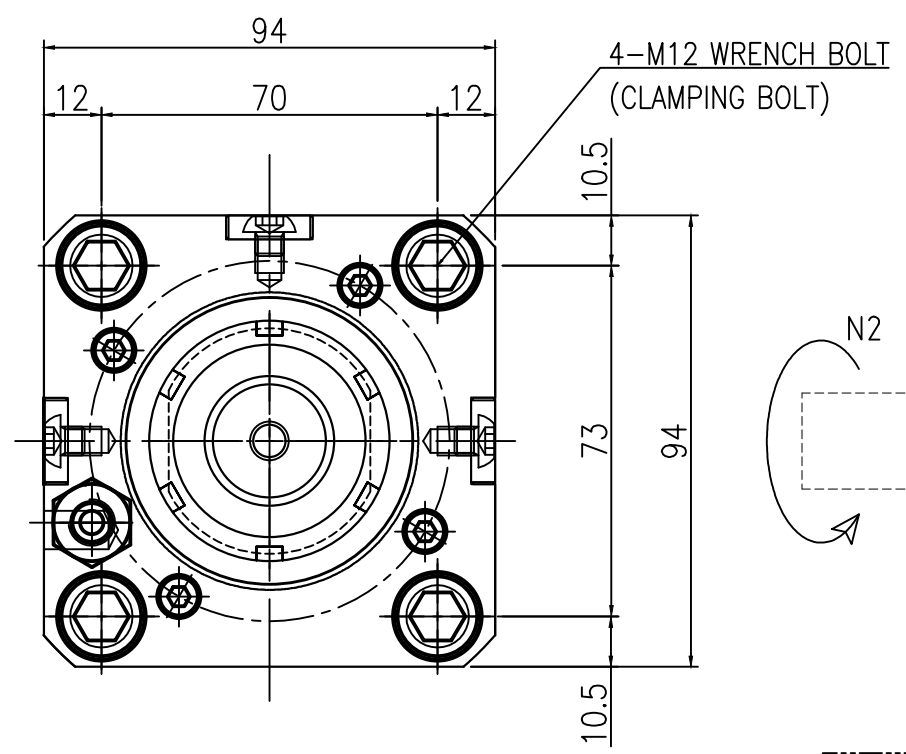

- Tool Spindle Size : ER 32
- MAX. RPM : 4000
- MAX. TORQUE : 70 Nm
- i= 1:1
- External Coolant System

GENERAL TOLERANCES (MACHING)				DWG	DGN	CHECK	APPR	MATERIAL	SCALE	Q'TY
RANGE	1ST G	2ND G	3RD G							
-6	±0.05	±0.1	±0.2					M/C NAME	AXIAL TOOL HOLDER	
6~30	±0.10	±0.2	±0.5					PART NAME	BMT65	
30~120	±0.15	±0.3	±0.8	DATE	2015-01-21			LAYOUT	WEIGHT	SHEET
120~315	±0.20	±0.5	±1.2	KASWIN			DWG NO.	KB65-AST-001		
315~1000	±0.30	±0.8	±2.0							
1000~2000	±0.50	±1.2	±3.0							