

HEAT TREAT :  
 SURF. TREAT :  
 GEN. CH. :

NO	DATE	SPEC. CHANGING	DGN	CH'G NO

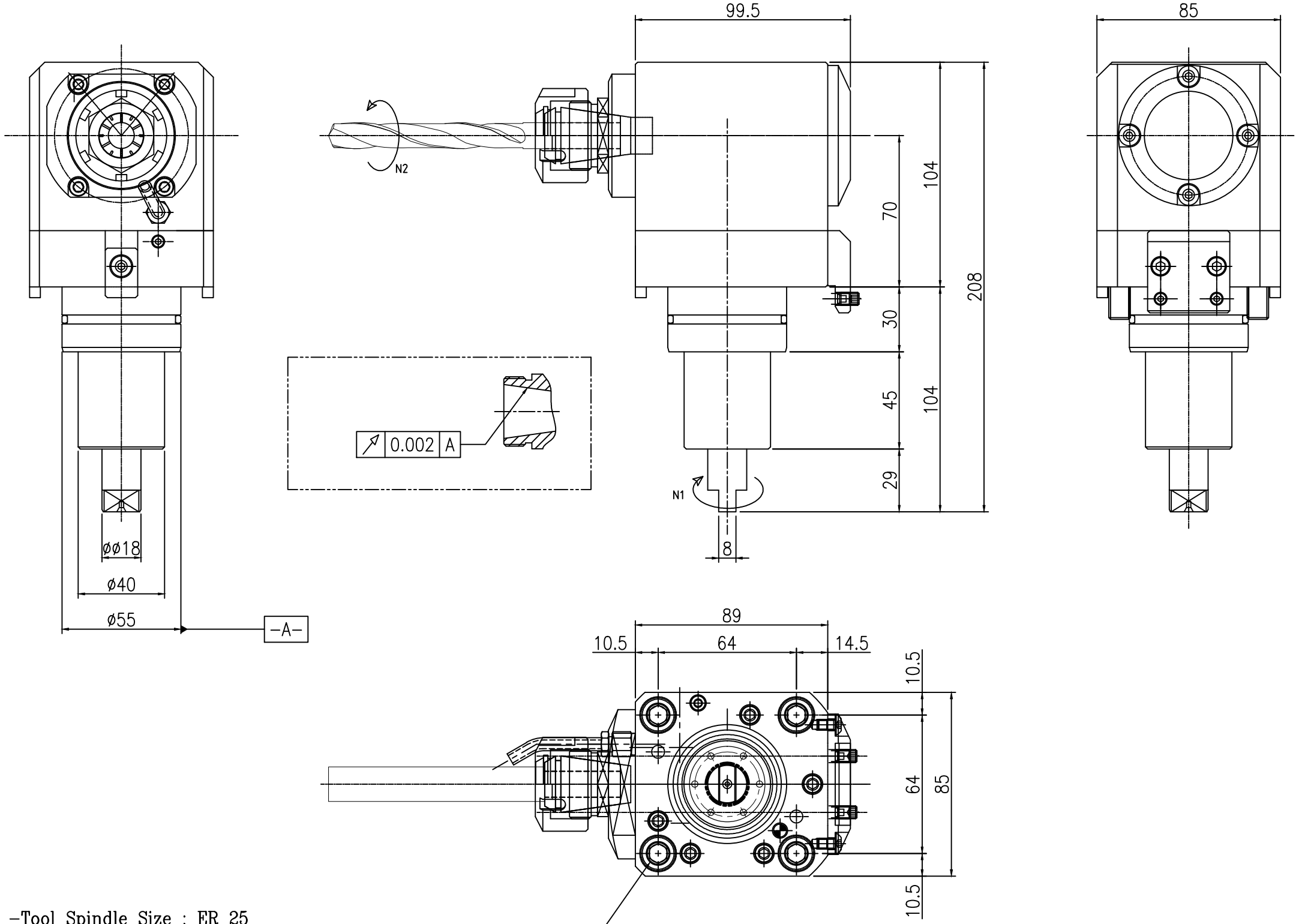

-Tool Spindle Size : ER 25  
 -MAX. RPM : 6000  
 -MAX. TORQUE : 40 Nm  
 i= 1:1  
 -External Coolant System

4-M10 WRENCH BOLT  
 (CLAMPING BOLT)

GENERAL TOLERANCES (MACHING)				DWG	DGN	CHECK	APPR	MATERIAL	SCALE	Q'TY	
RANGE	1ST G	2ND G	3RD G					M/C NAME	RADIAL TOOL HOLDER		
-6	±0.05	±0.1	±0.2					PART NAME	BMT55		
6~30	±0.10	±0.2	±0.5	DATE	2015-01-21			LAYOUT	WEIGHT	SHEET	
30~120	±0.15	±0.3	±0.8	<b>KASWIN</b>				DWG NO.	KB55-RST-001		
120~315	±0.20	±0.5	±1.2								
315~1000	±0.30	±0.8	±2.0								
1000~2000	±0.50	±1.2	±3.0								