

EXPLOSION PROOF FIXED CAMERA IVEX-FZ Series

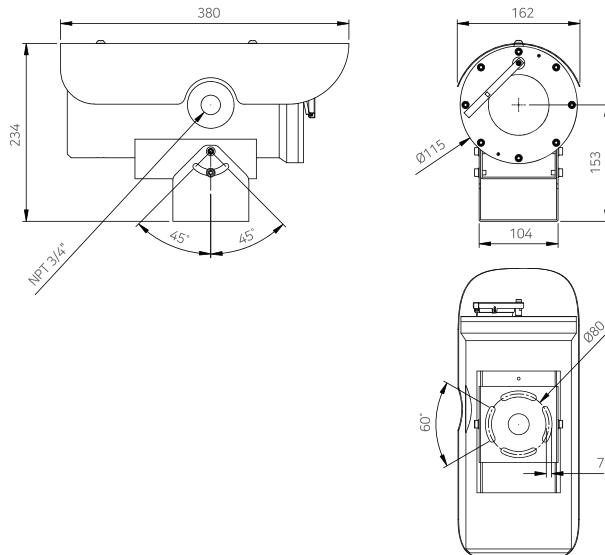

DIMENSIONS

Unit: mm



FEATURES

- Explosion proof Certificate : IECEx, ATEX, KCs, NEPSI
- Ex Grade : Ex d IIC T6 Gb IP67
EX tb IIIC T85°C Db, IP67
- Electro-polished 316L Stainless Steel Construction
- Operating Temperature :
-40°C ~ +67°C (-40°F ~ 152.5°F)
- Pan Travel Range ±60° (manually),
Tilt Travel Range ±45° (manually)
- Supports various protocols (auto selection)
- Cable Outlet : 1 EA (NPT 3/4")
- Built-in Fan / Heater, Window Defrost Heater (Option)
- Built-in Wiper Function
- Optional : Washer pump

SELECTION PRODUCT

- IVEX-FZ-10 HD-SDI Camera
- IVEX-FZ-20 SD Analog Camera
- IVEX-FZ-30 IP SD/HD Camera

SPECIFICATION

| | |
|---------------------------|--|
| Material of Body | Stainless Steel 316L |
| Material off Window Glass | Fully tempered plate glass |
| Ex Grade | Ex d IIC T6 Gb IP67, EX tb IIIC T85°C Db, IP67 |
| Certificate | IECEX, ATEX, KCs, NEPSI, CE, FCC, KC |
| Operating Temperature | -40°C ~ +67°C (-40°F ~ 152.5°F) |
| Operating Humidity | Less than 90% RH |
| Dimension | 380(L) x 160(W) x 234(H)mm (14.96" x 6.29" x 9.21") |
| Weight | Approx. 10 Kg (22.04 lb) |
| Input Voltage | 12 VDC(±10%), 110~230VAC, 50/60Hz(Optional) |
| Power Consumption | 50 Watt Max. |
| Cable Outlet | 1 EA (NPT 3/4") |
| Communication | RS-485 |
| Pan Travel Range | 60° (Manually) |
| Tilt Travel Range | -45° ~ +45° (Manually) |
| On-Screen Menu | On / Off |
| Fan / Heater | Built-in Fan / Heater, Window Defrost Heater(Optional) |
| Wiper | On / Off |
| Washer pump | Optional |
| Zoom Camera | IP / HD-SDI / Analog Type |