

방폭형 확산식 VOC 가스감지기

GTD-2000VOC

제품의 특징

- ▷ 내압방폭 구조로서 가스 누설 위험지역에 설치하여 VOC 가스를 연속적으로 감지
- ▷ 마이크로 프로세서를 적용한 자기진단기능 내장
- ▷ PID 센서 적용으로 저농도의 VOC 가스 측정
- ▷ 안정된 품질과 사용 수명이 검증된 감지원리 적용
- ▷ 다양한 기능을 내장한 고품질의 저렴한 제품
- ▷ Back-Light를 내장한 LCD or OLED 표시
- ▷ HART 통신으로 유지보수 및 모니터링 시스템 구축 용이
- ▷ 마그네틱 바를 이용하여 LCD or OLED 표시창과 1:1 대화 방식의 원격 교정 및 프로그램 설정
- ▷ 4-20mA DC 출력 신호
- ▷ 감지기 부착형 방폭 알람경광등과 가스감지기가 연동되어 동작
 - Normal : 초록색 LED
 - Alarm : 빨간색 LED, 부저 동작 (95dB)
 - Trouble : 노란색 LED
- ▷ 3-Wire Type
- ▷ 작업자 1인으로 교정 및 유지보수

Special Application



Alarm Beacon Type
(알람 경광등 부착형)



SIL 2

IEC 61508
Safety Integrity Level

General

Dimension (Unit:mm)

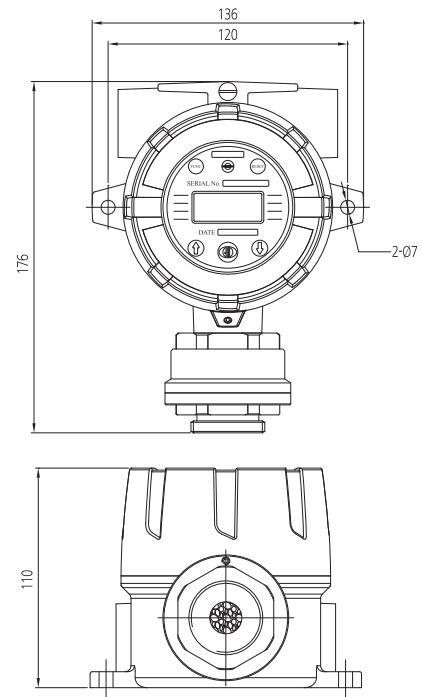
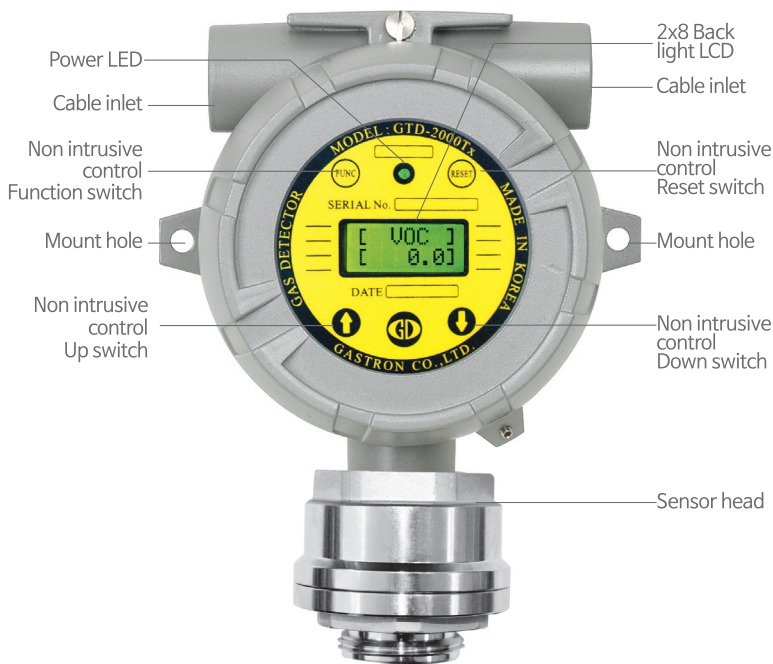

Accessories

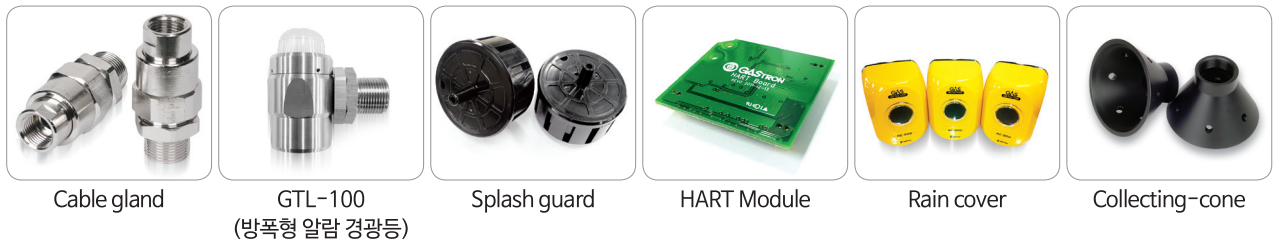

Specification

※Specifications are subject to be changed without prior notice.

SMART & LOCAL DISPLAY TYPE VOC GAS DETECTOR	
Model	GTD-2000VOC
Measuring gas	VOC gases(Benzene, Toluene, Xylene & etc)
Measuring type	Diffusion type
Measuring method	Photo-Ionization Detector(PID)
Measuring range	5ppb ~ 300ppm
Response time	< 5sec / 90% scale
Accuracy	±3% / Full scale
Parameter control	Non intrusive control with a Magnet bar (calibration, maintenance)
Operation mode display	1-LED (Power)
Measuring value display	LCD display (Built in back light 2-Line, 8 characters) / OLED Type (Option)
Output signal	Analog : Measuring signal : 4-20mA DC Calibration signal : 3mA DC Fault signal : 0mA DC Digital : 2mA (HART 7, HART Device Description Language available, Option)
Cable/Distance	Power + Signal cable : 3-wire >1.5sq (AWG16) / 2500m max
Material	Housing : ALDC, SUS316(Optional) / Sensor : SUS316
Conduit connection	M20 x 1.5P, M25x1.5P, NPT ½", NPT ¾"
Mounting type	2" Pole mount, Wall mount, Duct mount
Operating temperature	-20°C ~ +60°C / -40°C~80°C(Optional)
Operating humidity	5 ~ 99%.RH (non-condensing)
Operating power	18~31V DC (24V DC normal) / 200mA max
Dimensions	136x166x110 (WxHxD)mm
Weight	1.5kg
Approval	Explosion proof type (Ex d IIC T5) KCs / IP66/67 Explosion proof type (Ex d IIC Gb T4/T6) ATEX, IECEx Explosion proof type (Ex d IIC T5 Gb) NEPSI Marine : KR, MED, ABS, DNV CE, HART, SIL 2, UL