

DMT 25AL MARINE TRANSMISSION SPECIFICATION	
GEAR RATIO	1.64, 2.07, 2.52, 2.96, 3.32
TOTAL WEIGHT	APPROX. 77 Kg(DRY)
OIL CAPACITY	APPROX. 2L
OIL VISCOSITY	SAE # 30
OIL PRESSURE	1.96 ~ 2.35 MPa
DIRECTION OF ROTATION	INPUT C.C.W VIEWED FROM THE STERN
IN FORWARD	OUTPUT C.W VIEWED FROM THE STERN
OIL CHANGE INTERVAL	THE FIRST 100HOURS OF INITIAL OPERATION AND EVERY 1000HOURS THEREAFTER
SHIFTING LIMIT	UNDER 50% OF THE RATED ENGINE SPEED
OIL COOLER	WATER FLOW 20 ~ 40 L/m
	TEMPERATURE OF COOLING WATER MAX 32°C
OPERATING TORQUE OF SHIFTING LEVER	UNDER 2.94Nm

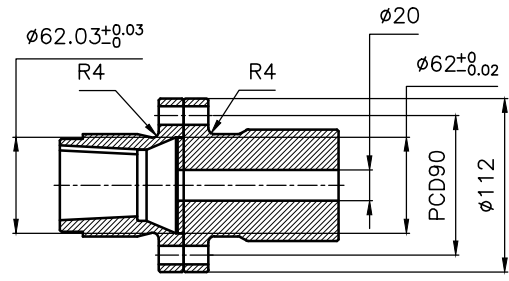

OUTPUT SHAFT COUPLING & PROPELLER COUPLING DIMENSION

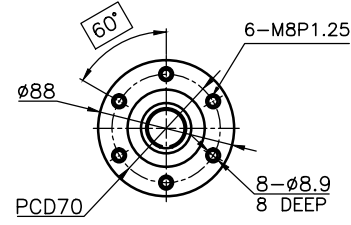

INPUT COUPLING DIMENSION

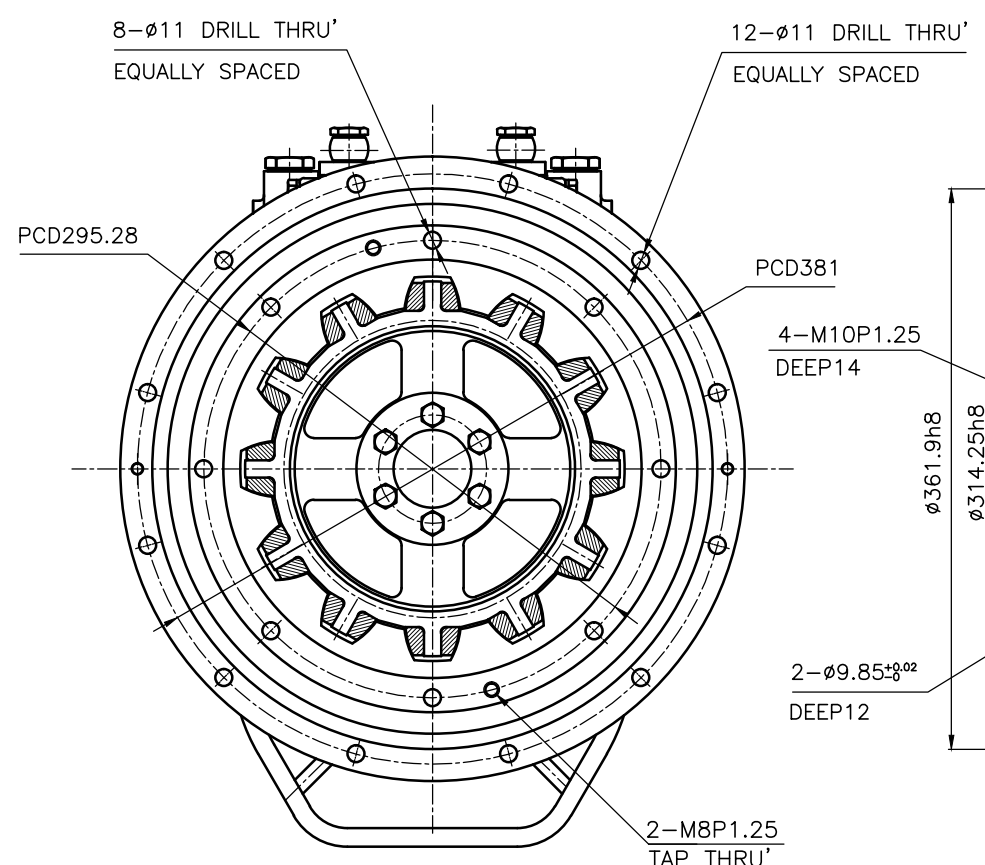
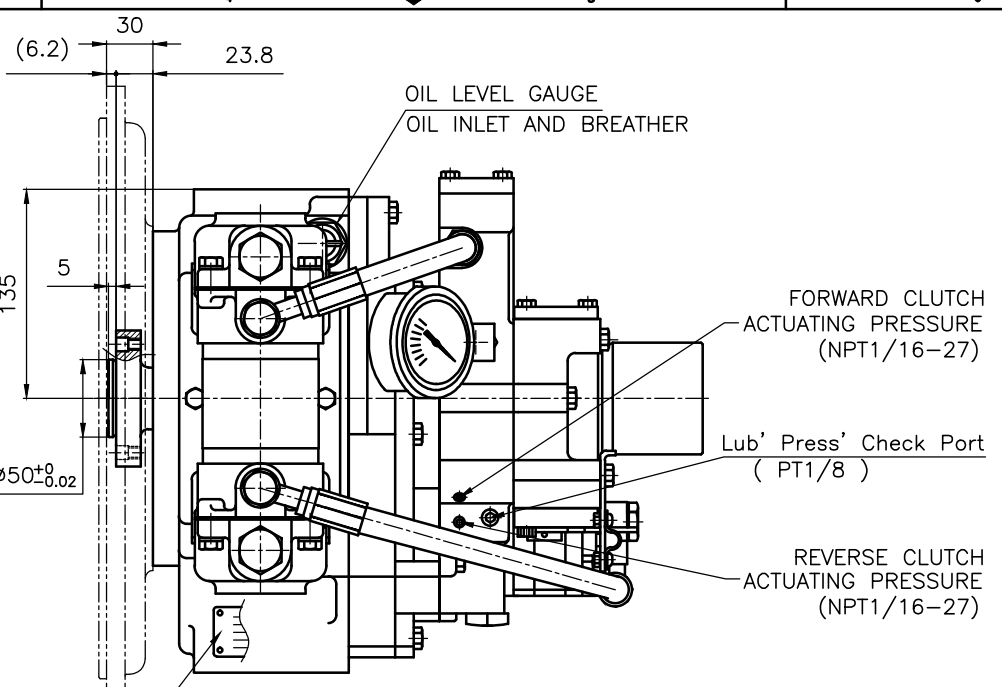

REMARK  
 1.HOUSING: SAE#4  
 2.DRIVING RING: SAE 10"  
 3.COULING TYPE : RUBBER

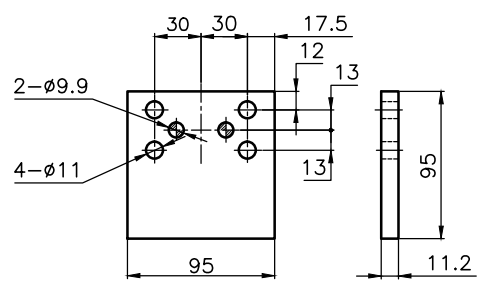

BRACKET DIMENSION

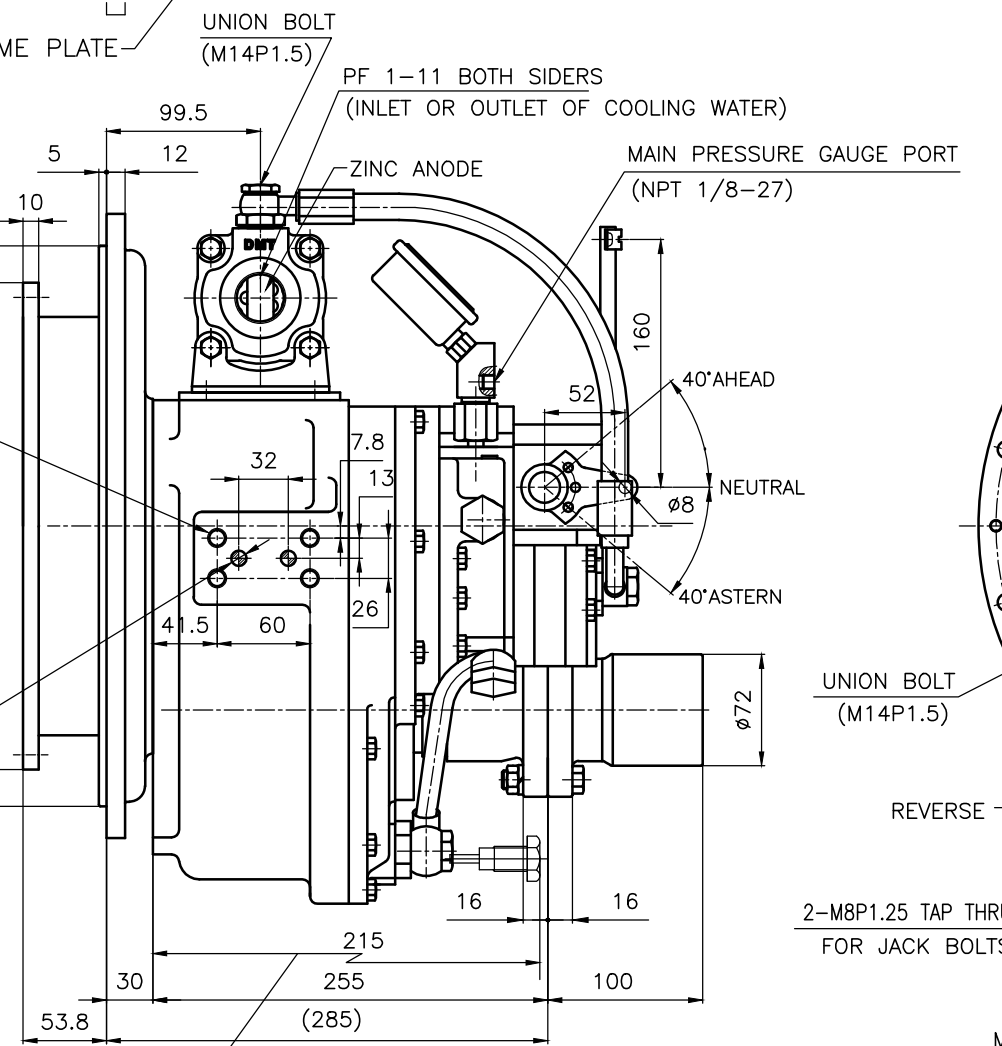

CLEARANCE TO REMOVE MAGNET PLUG

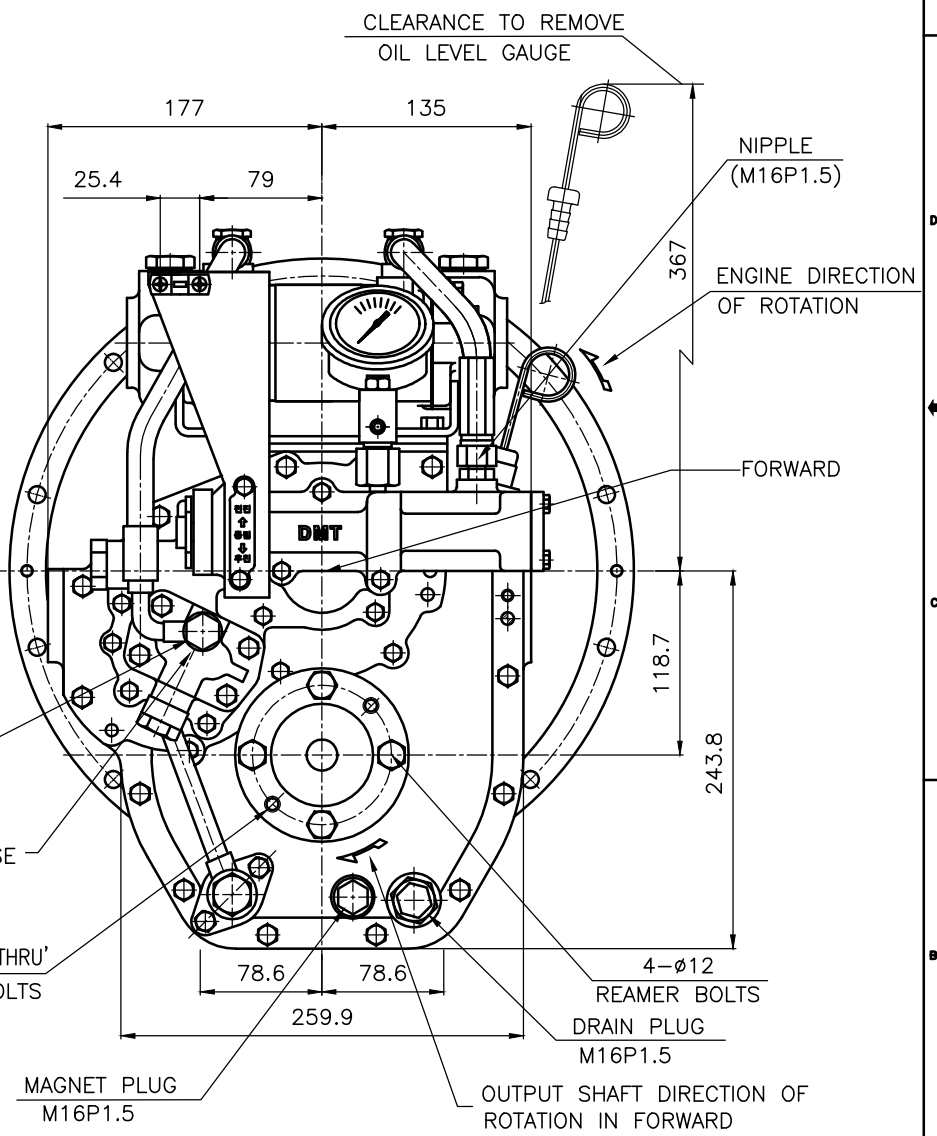

공통공차 TOLERANCE ON				번호 NO.	품 PART NO.	명 PART NAME	개수 QTY	재 MATERIAL	규 SIZE	비 REMARKS
분수 FRACTIONS	소수 DECIMALS	각도 ANGLES	공차 TOLERANCE							
$\pm$	$\pm$	$\pm$	$\pm$							
검사 기공										
구분	조립	종류	정밀							
1 초과 4 이하	$\pm 0.3$	$\pm 0.1$	$\pm 0.05$							
4	$\pm 0.5$	$\pm 0.2$	$\pm 0.07$							
16	$\pm 0.7$	$\pm 0.3$	$\pm 0.1$							
63	$\pm 1.2$	$\pm 0.5$	$\pm 0.2$							
250	$\pm 2.0$	$\pm 0.8$	$\pm 0.3$							

DATE 2012.06.18	SCALE N/S	TYPE DMT25AL	ORIGINAL DWG. NO.
APPROVED BY JK.Kim	CHECKED BY KS.Han	NAME MARINE TRANSMISSION	REV. 000
DRAWN KC.Yoon	DESIGNED	DWG. NO. 025000LA~E-410RC	계형(REV.)
D-I INDUSTRIAL		SIZE A 3	CODE ID. NO.